

Svalbard-F

Chilled beam for open installation
in ceiling or covering

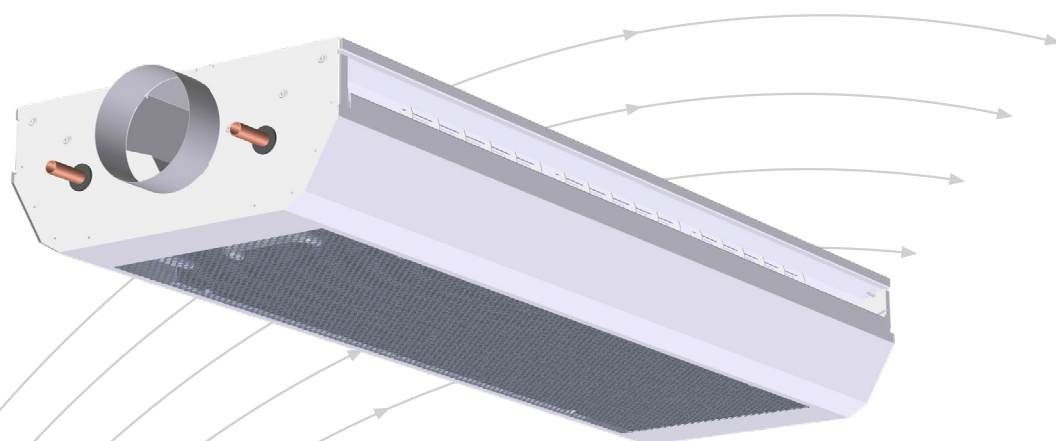

- Open installation
- Available in 1200mm to 3000mm lengths
- Adjustable pressure/air flow rate
- Variable flow pattern
- Dimensioning and simulation in AURASIM.

TROX[®] TECHNIK

 **Auranor**

TROX Auranor AS

Auranorvegen 6
NO-2770 Jaren

Telephone +47 61 31 35 00

e-mail: office-no@troxgroup.com
www.trox.no/en

Svalbard-F

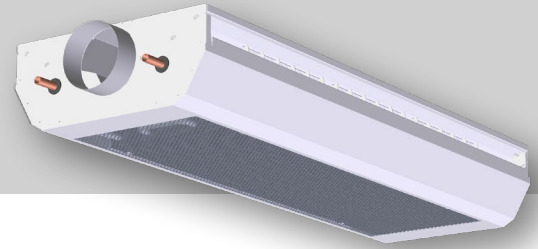

APPLICATION

Svalbard-F is a hydronic cooling, heating and ventilation system for use in offices, shops, schools etc. The system is designed to provide excellent cooling effect, and a high induction level ensures a draft-free environment in the occupied zone. Svalbard-F is designed for open installation in ceiling or covering.

FUNCTION

The primary air is supplied to the room through adjustable nozzles covering a large air volume range. The nozzles are factory-calibrated to the desired relationship between the unit's pressure drop and the supplied primary air volume to achieve the desired operating point. Svalbard-F has a two-way distribution of air into the room; it draws in room air through the coil for cooling or heating, depending on the selected coil type. The baffle ensures good induction of supplied air into the room, ensuring a draft-free comfort zone. Svalbard-F is equipped with the Jet-Split system in the unit's side slots, providing the possibility to alter the dispersion pattern.

DESIGN

- Nozzle configuration for the chilled beam, i.e. desired air supply and pressure, is specified at time of order.
- Svalbard-F is delivered with integrated pressure outlet for air flow rate measurements.
- The front panel can be folded down for inspection and cleaning.
- Svalbard-F is available in installation lengths of 1200, 1800, 2400 and 3000 mm.
- Dispersion options: symmetrical 50/50 or asymmetrical 75/25 (25/75) – can be adjusted on site.
- Connection to air: gable end $\varnothing 125$ mm (spigot dimension).
- Connection to water: Cu $\varnothing 15 \times 1,0$ mm.
- Changeable flowpattern via Jet Split lamellae in the beams outlet.
- Blind cover can be provided for adaptation to the wall. See Figure 8.

MATERIALS AND SURFACE COATING

Frame and casing in a galvanised, steel-plated finish. Delivered in a powdered painted finish (white RAL 9003 - gloss 30) as standard. Copper tube coils with aluminium lamellae. Adjustable lamellae are in a plastic design.

DIMENSIONS AND WEIGHT, Svalbard-F

Length [mm]	L [mm]	Weight * [kg]	Weight: water in cooling coil [kg]		
			SKB	HKB	VKB
1200	1200	19	0,5	1,0	0,8
1800	1800	27	0,8	1,5	1,2
2400	2400	35	1,0	2,1	1,5
3000	2994	45	1,3	2,6	2,0

Table 1 (* No water in cooling coil)

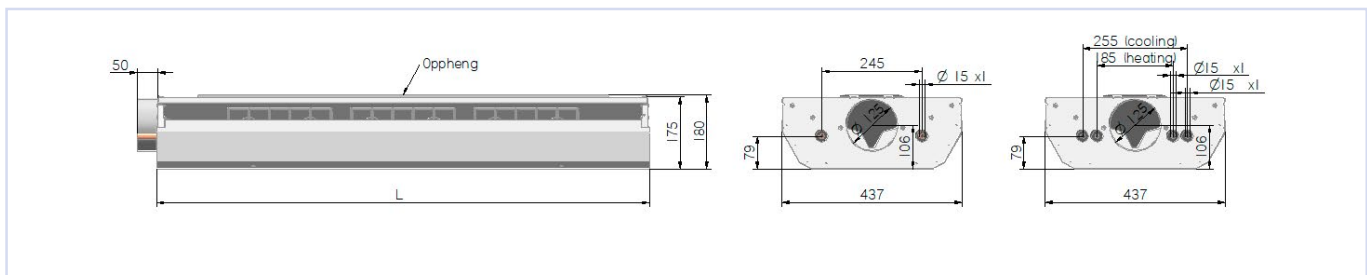

Fig. 2

ACCESSORIES

See order code, delivered loose/unassembled..
 W = TROX TRV 2-way valve, Broen (see separate data sheet).
 A1 = Actuator 24V on/off, Broen (see separate data sheet).
 A2 = Actuator 230V on/off, Broen (see separate data sheet).

ACCESSORIES

Ordered and delivered loose/unassembled..
 Ballorex Dynamic valve (see separate data sheet).
 Actuator: 24V, 230V or 24V modulating 0 - 10V signal.
 Transformer, EasyTrafo 75 VA (see separate data sheet).
 Transformer, EasyTrafo 105 VA (see separate data sheet).
 Room controller, EasyReg (see separate data sheet).

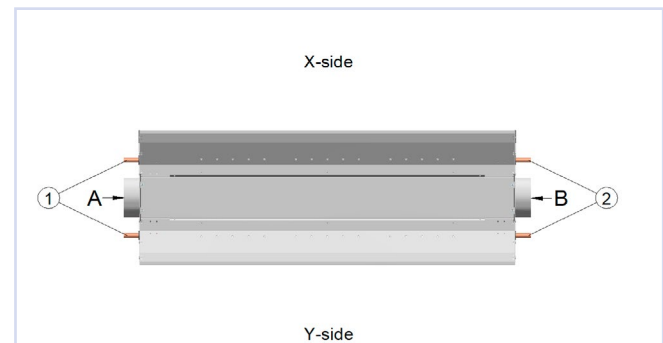
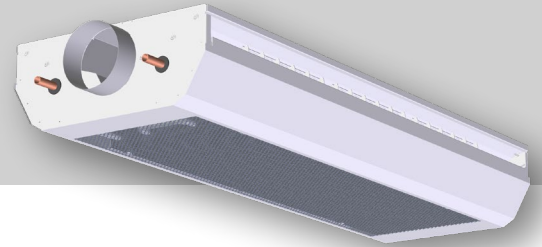

Fig. 1

Svalbard-F



ORDER CODE, Svalbard-F

Svalbard-F-1800-104-SKB-A-50/50-1-W-A1-S-0

1 2 3 4 5 6 7 8 9 10 11

1 Type/variant

Svalbard F, suspended installation

7 Water connection*

1 eller 2

2 Length

1200, 1800, 2400 eller 3000

8 Water valve

0 without water valve

W TRV-2-way valve, delivered loose/unassembled**

3. Adjustment factor

Auracoolfactor

9 Actuator

0 uten aktuator

A1 actuator 24V, delivered loose/unassembled**

A2 actuator 230V, delivered loose/unassembled**

4. Coil type

SKB standard cooling coil

HKB high-capacity coil

VKB heating and cooling coil

10 Damper

0 without damper

S with damper DRS-K 125**

5. Air connection*

A eller B

11 Exposed surface

0 RAL 9003

SL-RAL special finish RAL

SL-NCS special finish NCS

6.Flow pattern

0 standard 50/50

25/75 asymmetrical, x= 25/ y=75

75/25 asymmetrical, x= 75/ y= 25

* The standard air and water connections are at the same gable end: A1 or B2, see Figure 1.

** accessories supplied loose/unassembled.

Exempel: Svalbard-F-1800-104-SKB-A-50/50-1-W-A1-S-0

Type/variant	Svalbard-F
Length	1800
Adjustment factor	104
Coil type	SKB
Air connection*	A
Flow pattern	50/50
Water connection*	1
Water valve	W
Actuator	A1
Damper	S
Exposed surface	0 RAL 9003

Svalbard-F

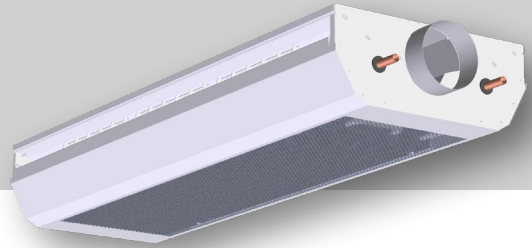

QUICK SELECTION, Svalbard-F

The tables state the cooling effect from the chilled beam's water circuit, and the emitted sound power level from the beam. In order to calculate total cooling effect, the cooling effect of the supply air must be added as shown in the example below.

Example			
Product:	Svalbard-F 1800		
Battery type:	Standard	Water-side cooling effect at 40 Pa as per table 3 =	580 W
Air flow rate:	75 m ³ /h	Supply-air cooling effect: $q/3600 \times 1,2 \times c_p \times \Delta t_{\text{room-supply air}}$ =	
$\Delta t_{\text{room-water}}$:	10°K	$75/3600 \times 1,2 \times 1010 \times 6 =$	152 W
$\Delta t_{\text{room-supply air}}$:	6°K	Total cooling effect =	732 W

Svalbard-F-1200 mm

Δt_k [°C]	6				8				10				L_w		
Total pressure in duct [Pa]	40		80		40		80		40		80		dB(A)		
Coil type	SKB	HKB	SKB	HKB	SKB	HKB	SKB	HKB	SKB	HKB	SKB	HKB	40 Pa	80 Pa	
Air flow rate [m ³ /h]	40	210	250	240	280	330	320	370	350	410	410	470	<20	27	
	60	240	280	270	330	330	380	390	440	410	470	550	<20	28	
	80	260	300	300	340	340	390	400	460	420	510	510	600	24	30
	100	270	320	320	360	360	420	430	490	450	550	550	650	27	32
	120	280	340	330	380	380	440	450	520	470	570	570	680	31	35

Table 2: Cooling effects at 0.06 litres of water per sec.

Svalbard-F-1800 mm

Δt_k [°C]	6				8				10				L_w	
Total pressure in duct [Pa]	40		80		40		80		40		80		dB(A)	
Coil type	SKB	HKB	SKB	HKB	SKB	HKB	SKB	HKB	SKB	HKB	SKB	HKB	40 Pa	80 Pa
Air flow rate [m ³ /h]	50	300	350	340	400	460	440	520	500	580	560	640	<20	24
	75	340	400	380	460	520	500	600	580	660	640	740	<20	26
	100	380	450	420	500	580	560	680	620	700	680	820	22	30
	125	400	480	460	550	640	620	740	700	780	760	880	26	32
	150	420	500	480	580	680	660	780	740	840	820	940	29	34

Table 3: Cooling effects at 0.06 litres of water per sec

Svalbard-F-2400 mm

Δt_k [°C]	6				8				10				L_w	
Total pressure in duct [Pa]	40		80		40		80		40		80		dB(A)	
Coil type	SKB	HKB	SKB	HKB	SKB	HKB	SKB	HKB	SKB	HKB	SKB	HKB	40 Pa	80 Pa
Air flow rate [m ³ /h]	60	400	440	440	500	580	540	640	620	720	680	800	<20	24
	90	440	500	480	600	680	640	740	700	800	760	900	<20	26
	120	480	560	540	640	740	720	840	800	920	900	1060	23	29
	150	520	620	580	680	780	760	880	840	980	980	1040	26	32
	180	550	660	620	740	840	820	960	900	1040	1040	1200	30	35

Table 4: Cooling effects at 0.06 litres of water per sec.

Svalbard-F-3000 mm

Δt_k [°C]	6				8				10				L_w		
Total pressure in duct [Pa]	40		80		40		80		40		80		dB(A)		
Coil type	SKB	HKB	SKB	HKB	SKB	HKB	SKB	HKB	SKB	HKB	SKB	HKB	40 Pa	80 Pa	
Air flow rate [m ³ /h]	80	486	556	538	620	763	714	818	815	947	898	1038	<20	26	
	110	538	623	718	819	724	822	813	937	907	1044	1001	1175	<20	29
	140	574	677	657	782	784	923	902	1035	987	1141	1098	1304	25	31
	170	616	723	698	835	824	955	959	1096	1039	1224	1173	1421	28	34
	200	638	749	740	860	864	1000	975	1135	1089	1263	1259	1514	32	37

Table 5: Cooling effects at 0.06 litres of water per sec.

Svalbard-F

DIMENSIONING

For accurate dimensioning, please use the Aurasim software available for download at our website: www.trox.no or aurasim.no. The software enables selection of the optimum chilled beam for the prevailing conditions. Among the factors calculated in Aurasim are:

- Cooling effect
- Heating effect
- Sound power level
- Sound attenuation
- Pressure drop air/water
- Appropriate positioning

Calculate the cooling and heating effect in the simulation program Aurasim, available on: www.trox.no or aurasim.no

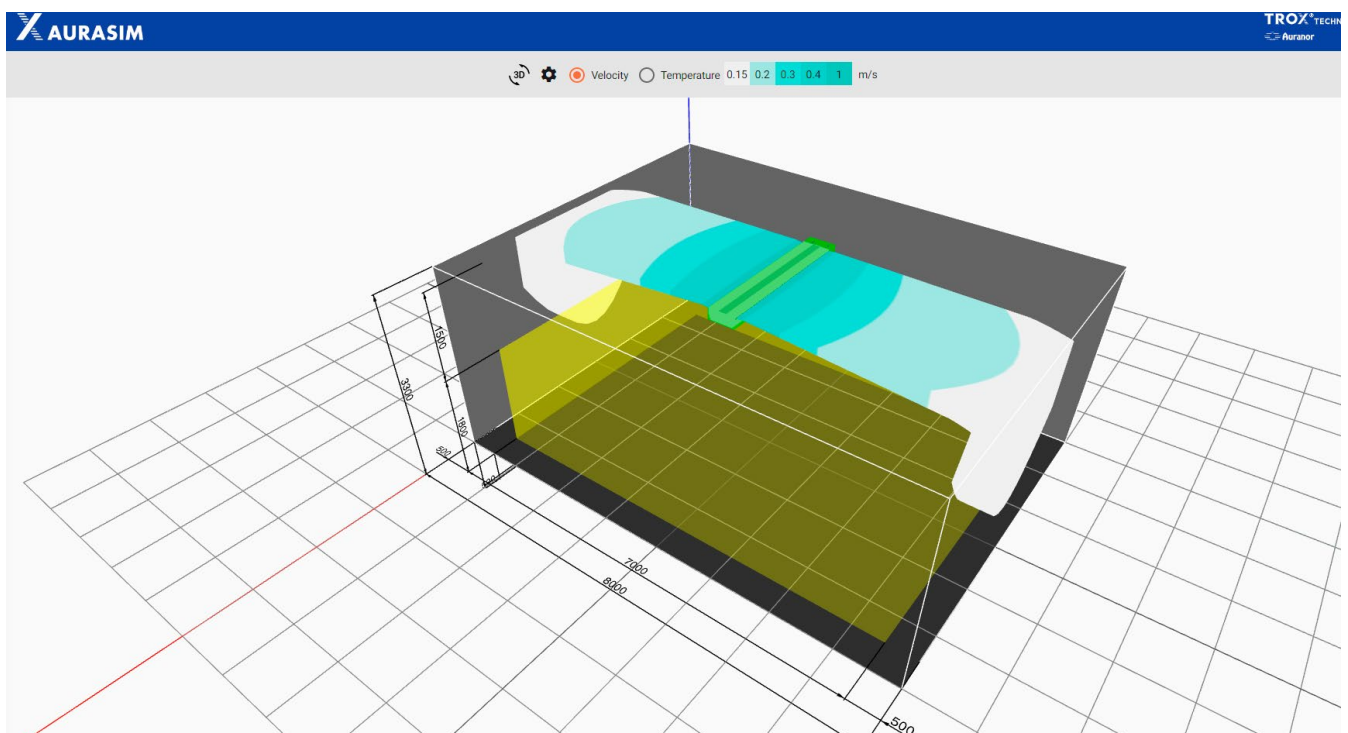

Fig.3.

TECHNICAL DATA FOR COMMISSIONING DAMPER DRS-K Ø125.

Diagram 1 shows total pressure drop over the damper alone as a function of air flow rate. The graphs represent A-weighted sound pressure level. Table 7 provides the correction factor [KO] for conversion to various frequency levels. Correction factors shown in the diagram are for open damper (right/lower line) and closed damper (left/upper line). Open is equivalent to a damper angle of 0°. The correction factors for intermediate points are interpolated between these. Sound power level for each frequency is calculated using the formula: $L_{W_{okt}} = L_{WA} + KO$ where L_{WA} is sound pressure level obtained from diagram 1.

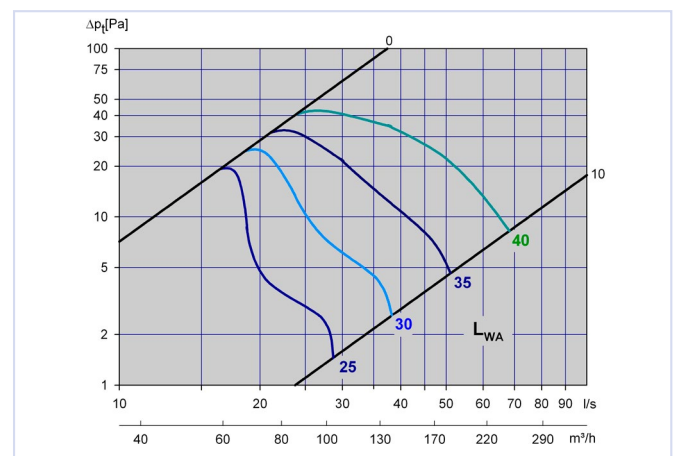

Diagram 1
Pressure drop and sound pressure level for commissioning damper DRS-K Ø125

Svalbard-F

Correction factor [K0], DRS-K Ø125

DRS-K	Octave band (Hz)							
	63	125	250	500	1k	2k	4k	8k
Damper open(10)	19	5	1	-3	-9	-12	-16	-1
Damper closed(0)	17	0	5	-10	-14	-9	-8	-19

Table 6: Correction factors for conversion to sound power level at the respective frequencies.



Fig. 4, DRS-K Ø125

FLOW PATTERN

The direction and angle of the flow pattern can be adjusted via Jet Split lamella. This can be visualised in the Aurasim software available for download at our website: www.trox.no or aurasim.no.

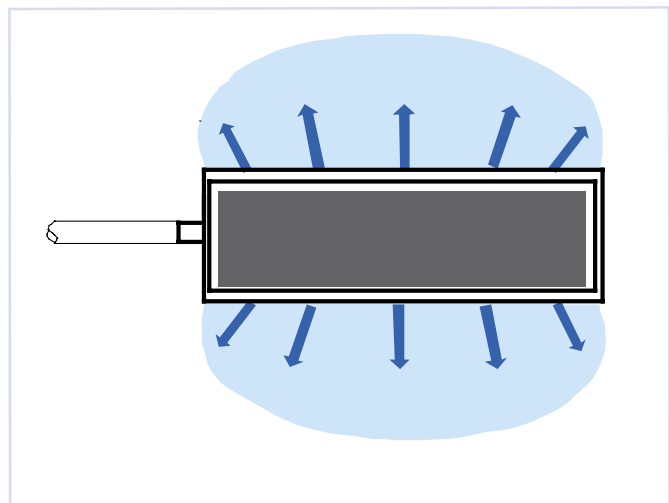

Fig.5: Flow pattern

THROW LENGTH

Appropriate positioning in order to prevent high velocities in the occupied zone is calculated by using the product selection software Aurasim available for download via our website: www.trox.no or aurasim.no.

Svalbard-F

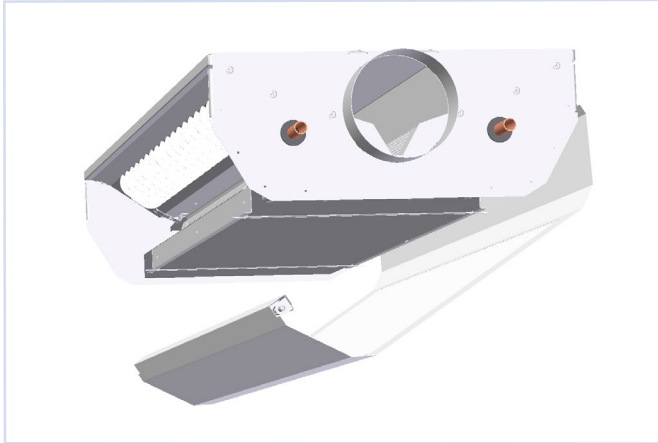

Fig. 6: Svalbard-F, installation

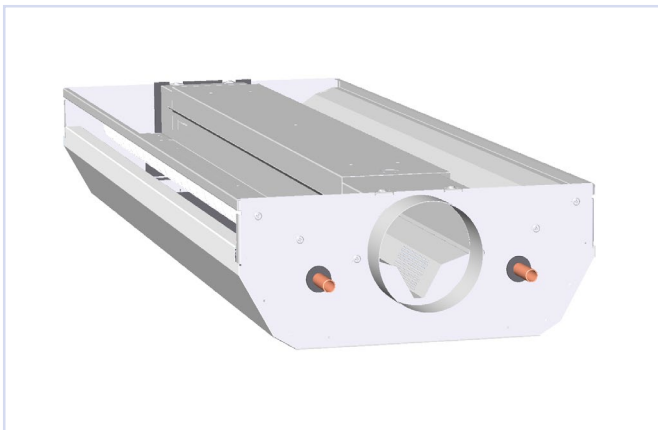
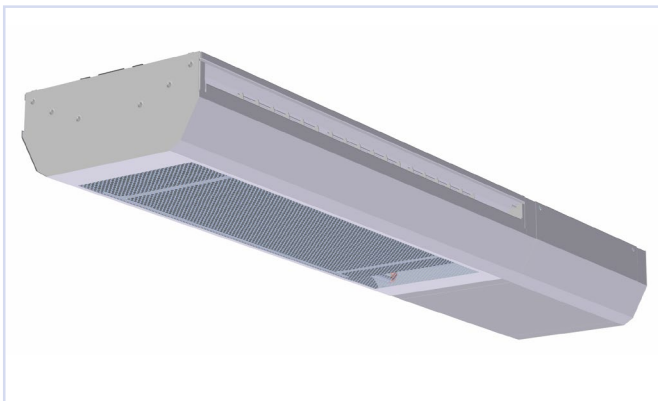

Fig. 7: Svalbard-F, installation



Figur 8. Svalbard-F blind cover.

INSTALLATION

Svalbard-F is supplied with a mounting bar for attachment to ceiling or covering (fig. 7). Detailed installation instructions is to be found on our website: trox.no

INSTALLATION, water valve

The water valve should be placed on the return, that is, with arrow on the valve away from the cooling battery.

The cooling batteries in Svalbard-I are not directional, so the return can be connected at your own request. The water valve is directional.

COMMISSIONING

Svalbard-F will have a pre-set air flow rate and pressure in accordance with the details specified. The pre-set value and correction factor will be specified on an appropriately positioned label which is visible when the front is folded down.

If required, the air flow rate can be adjusted on site. New nozzle positions can be obtained from the factory or in Aurasim which can be downloaded from our website: www.trox.no or aurasim.no.

Max. working pressure waterside 10 bars.

Max. test pressure waterside 15 bars.

MAINTENANCE

Full access to the coil is achieved by folding down the front panel as shown in fig. 6.

Vacuuming and, if required, using a damp cloth to clean the unit is recommended.

ENVIRONMENT

Enquiries regarding product declaration can be directed to our sales team, or information can be found at our website: www.trox.no

Svalbard-F is developed and manufactured by:

The company reserves the right to make amendments without prior notice.