

Svalbard-F Comfort

Chilled beam with integrated VAV-function

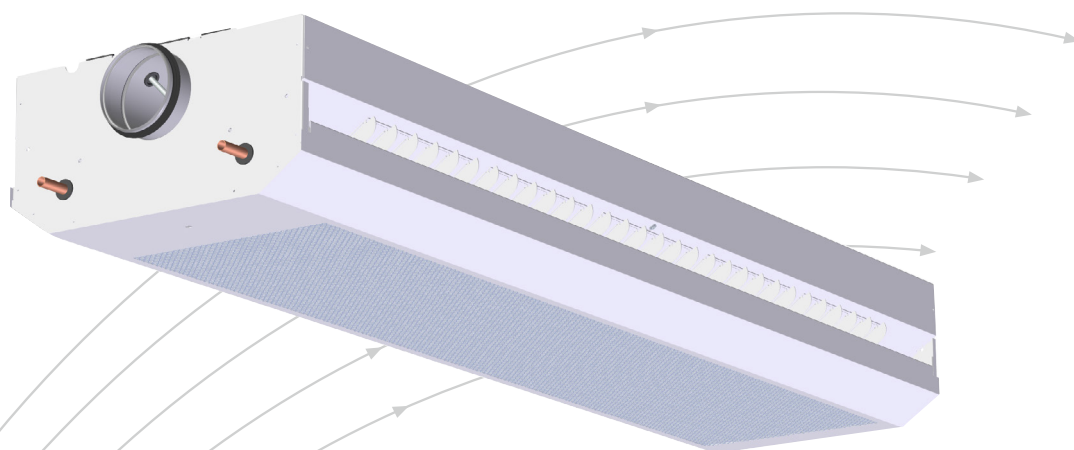

- Open installation
- Available in 1200 mm to 2400 mm lengths
- Pressure independent VAV-function integrated
- Constant induction factor secured by integrated controller
- Bluetooth communication and app for commissioning and service
- Design and dimensioning by AURASIM
- VDI 6022 certified

TROX[®] TECHNIK

 **Auranor**

TROX Auranor Norge AS

Auranorvegen 6
NO-2770 Jaren

Telephone +47 61 31 35 00
E-mail: firmapost@auranor.no

www.trox.no



Svalbard-F Comfort

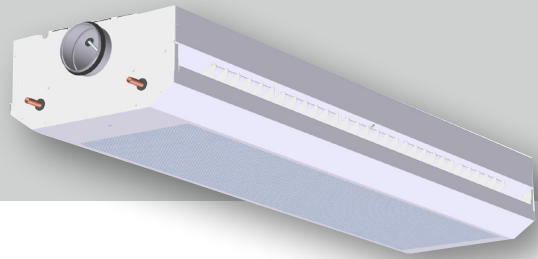

APPLICATION

Svalbard-F Comfort is a hydronic cooling, heating and ventilation system for use in offices, shops, schools etc. The system is designed to provide a draft-free cooling effect in the occupied zone. Svalbard-F Comfort is designed for open installation in ceiling or covering.

FUNCTION

Svalbard-F Comfort has an integrated and pressure independent VAV-damper, which controls the primary air volume to the requested setpoint, and adjust the nozzles accordingly with a secondary actuator. The VAV-damper and nozzle opening are controlled by an integrated controller in the unit, which secures a constant nozzle velocity, independent of the primary air volume. The controller can be controlled by analogue input or Modbus RTU communication. For service and commissioning the app TROX ECA is used, which communicates wireless by Bluetooth. Svalbard-F Comfort can be connected to TROX X-AIRCONTROL (fig. 3) with a RJ12 cable, and communicates then by Modbus. More information of X-AIRCONTROL can be found on our website www.trox.no/en. Air is supplied via nozzles, and indoor air is extracted and fed through the coil. Effective mixing of indoor air and supply air, i.e. induction, minimises the risk of draft in the occupied zone. When Svalbard-F Comfort is used for heating, the same technique is used for dispersion of heat along the ceiling.

DESIGN

Svalbard-F Comfort has an integrated VAV-damper and adjustable nozzles, which is controlled by two actuators. Access to the actuators is shown in fig. 1 and fig. 2. The controlling is made by a controller placed behind the front panel. The coil for heating and cooling can be delivered in three options, standard cooling, high capacity cooling or combined cooling and heating. The perforated front panel can be folded down for cleaning of coil and easy access to actuator. The duct connection for primary air is spiro duct Ø125, and the water connection is Ø15 copper pipes. In the beam outlet the flow pattern can be adjusted by Jet Split lamellaes. Blind cover can be provided for adaption to the wall. See Figure 12.

MATERIALS AND SURFACE COATING

Svalbard-F Comfort is produced in galvanised steel, and visual parts are powder coated in RAL 9003 gloss 30. The measuring cross are aluminium, hoses and fittings are plastic. The coil has copper tubes and aluminium lamellaes. The duct connection is fitted with EPDM rubber gasket.

ACCESSORIES

Ordered separately and delivered unmounted. Ballorex dynamic valve. See separate documentation. Actuator for valve: on/off 24 V or 230 V, or 24 V modulation 0-10 V signal.

ORDER CODE, Svalbard-F Comfort

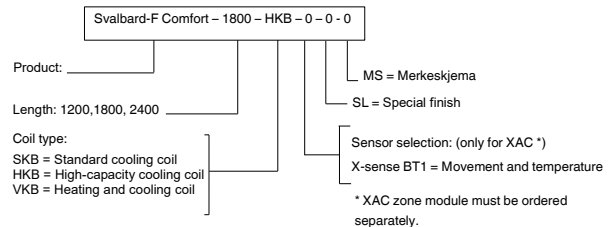

Example:
Svalbard-F Comfort - 1800 - HKB - 0 - 0 - 0

Explanation:
Svalbard-F Comfort for open installation, length 1800 mm with high-capacity cooling coil, powder coated RAL 9003, without labeling scheme

ORDER CODE, BLIND COVER

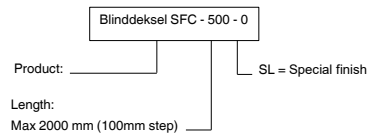

Example:
Blinddeksel SFC - 500 - 0

Explanation:
Blind cover Svalbard-F Comfort, length 500 mm, powder coated RAL 9003

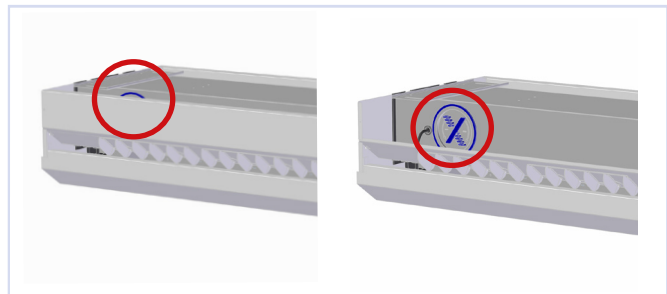
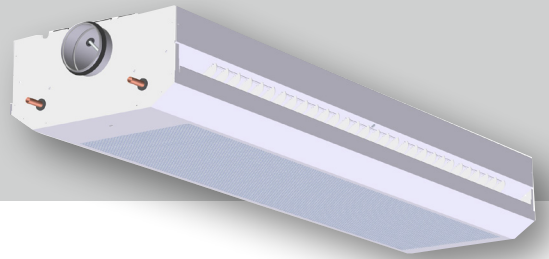

Figure 1. Inspection hatches for actuators.



Figure 2. Inspection hatch for nozzle opening controls.

Svalbard-F Comfort



DIMENSIONS AND WEIGHT, Svalbard-F Comfort

Length	L	L2	Weight*	Weight: water in coil [kg]		
				SKB	HKB	VKB
1200	1200	1030	21	1,0	1,3	1,3
1800	1800	1630	29	1,5	1,9	1,9
2400	2400	2230	37	2,1	2,6	2,6

Table 1. Dimension and weight (*without water in coil).

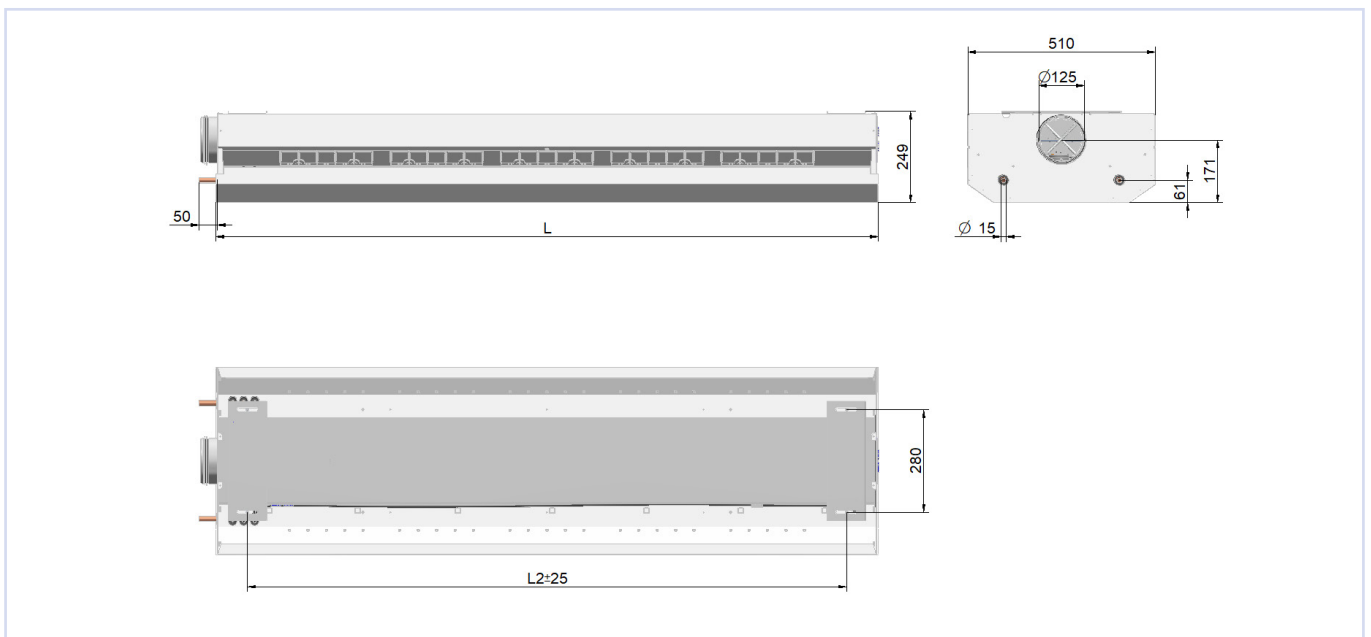

Figure 3, Svalbard-F Comfort dimensions

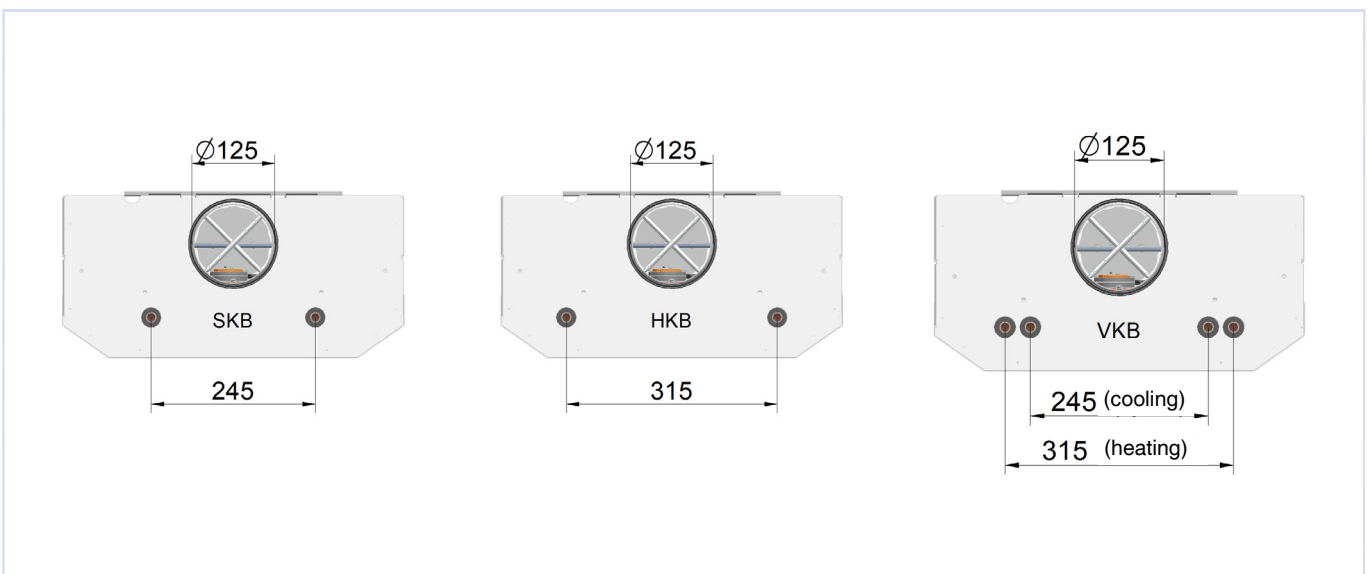

Figure 4, connection cooling/heating

Svalbard-F Comfort

DIMENSIONING, SUPPLY

Cooling- and heating capacity can be calculated by simulation tool AURASIM which can be found at www.aurasim.no

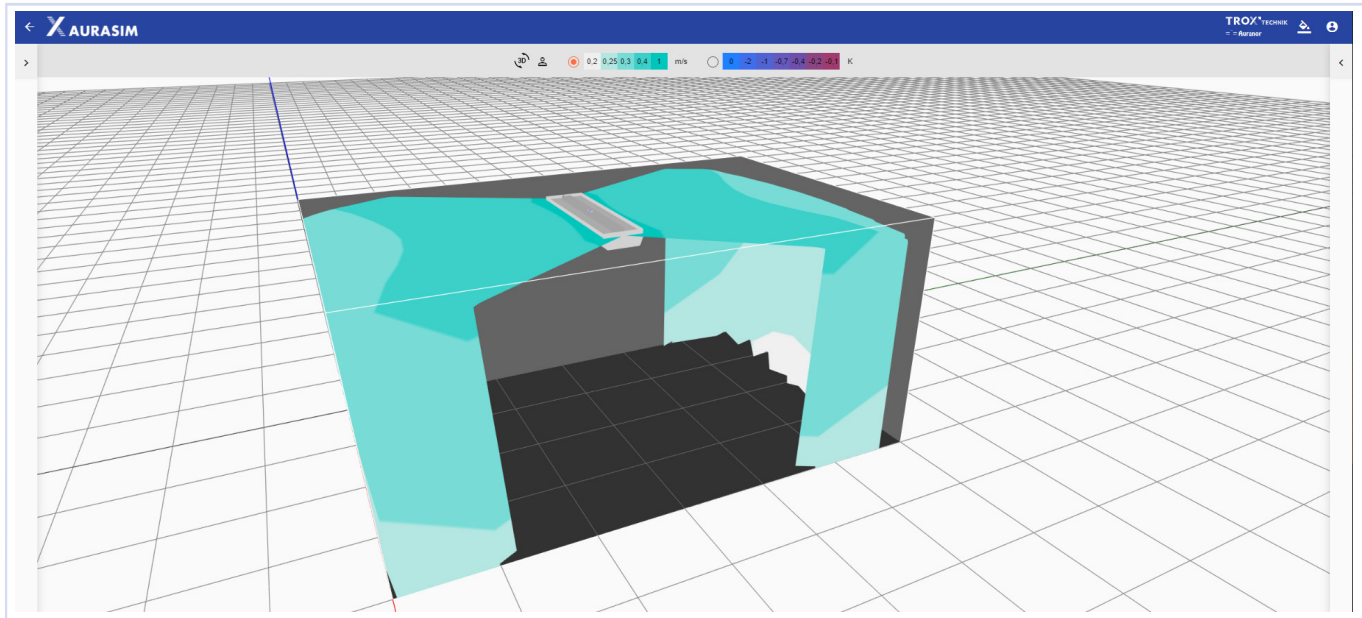

Figure 5, AURASIM

DIMENSIONING, COOLING CAPACITY WATER

SKB (8-pipe) and HKB (10-pipe) coil

Svalbard-F Comfort 1200

		Cooling capacity water [W]																
Δt_k [°C]		6				8				10				12				
Pt [Pa]		60		80		60		80		60		80		60		80		L_{WA}
Coil		SKB	HKB	SKB	HKB	SKB	HKB	SKB	HKB	SKB	HKB	SKB	HKB	SKB	HKB	SKB	HKB	[dB(A)]
Air volume [m³/h]	60	311	331	345	367	430	469	458	488	545	585	571	614	658	706	671	720	21-24
	75	332	355	374	399	467	502	496	529	585	622	615	665	700	750	719	770	22-26
	90	351	375	399	429	494	532	530	565	622	655	660	715	740	792	770	825	23-29
	110	372	396	429	463	530	565	574	617	662	705	719	778	791	848	831	890	31-34

Table 2

Water volume given: $q_w = 0,06$ l/s

Explanation: Δt_k = Room temperature - middle water temperature.

Svalbard-F Comfort 1800

		Cooling capacity water [W]																
Δt_k [°C]		6				8				10				12				
Pt [Pa]		60		80		60		80		60		80		60		80		L_{WA}
Coil		SKB	HKB	SKB	HKB	SKB	HKB	SKB	HKB	SKB	HKB	SKB	HKB	SKB	HKB	SKB	HKB	[dB(A)]
Air volume [m³/h]	90	462	498	487	525	616	661	657	705	769	825	819	877	923	988	981	1057	24-27
	110	495	535	530	568	665	715	702	760	830	895	880	945	997	1070	1060	1140	27-30
	130	530	572	565	600	711	766	745	805	888	955	940	1006	1062	1140	1130	1208	29-31
	150	564	610	597	633	754	808	796	852	945	1010	994	1063	1127	1213	1193	1274	31-35

Table 3

Water volume given: $q_w = 0,06$ l/s

Explanation: Δt_k = Room temperature - middle water temperature.

Svalbard-F Comfort

Svalbard-F Comfort 2400

		Cooling capacity water [W]																L_{WA} [dB(A)]
		6				8				10				12				
Δt_k [°C]	Pt [Pa]	60		80		60		80		60		80		60		80		
Coil		SKB	HKB	SKB	HKB	SKB	HKB	SKB	HKB	SKB	HKB	SKB	HKB	SKB	HKB	SKB	HKB	
Air volume [m³/h]	90	515	555	562	604	685	743	752	806	861	922	942	1007	1030	1109	1124	1209	
	110	580	628	610	658	775	835	820	880	960	1032	1020	1095	1160	1250	1220	1320	
	130	645	695	665	712	860	925	890	950	1065	1145	1105	1185	1280	1385	1325	1420	
	150	704	755	713	764	942	1006	954	1019	1170	1258	1194	1274	1407	1510	1426	1529	

Table 4

Water volume given: $q_w=0,06$ l/s

Explanation: Δt_k = Room temperature - middle water temperature.

FLOW PATTERN, Svalbard-F Comfort

The flow pattern can be adjusted by Jet Split, and this can be visualized by simulation tool AURASIM.

www.aurasim.no

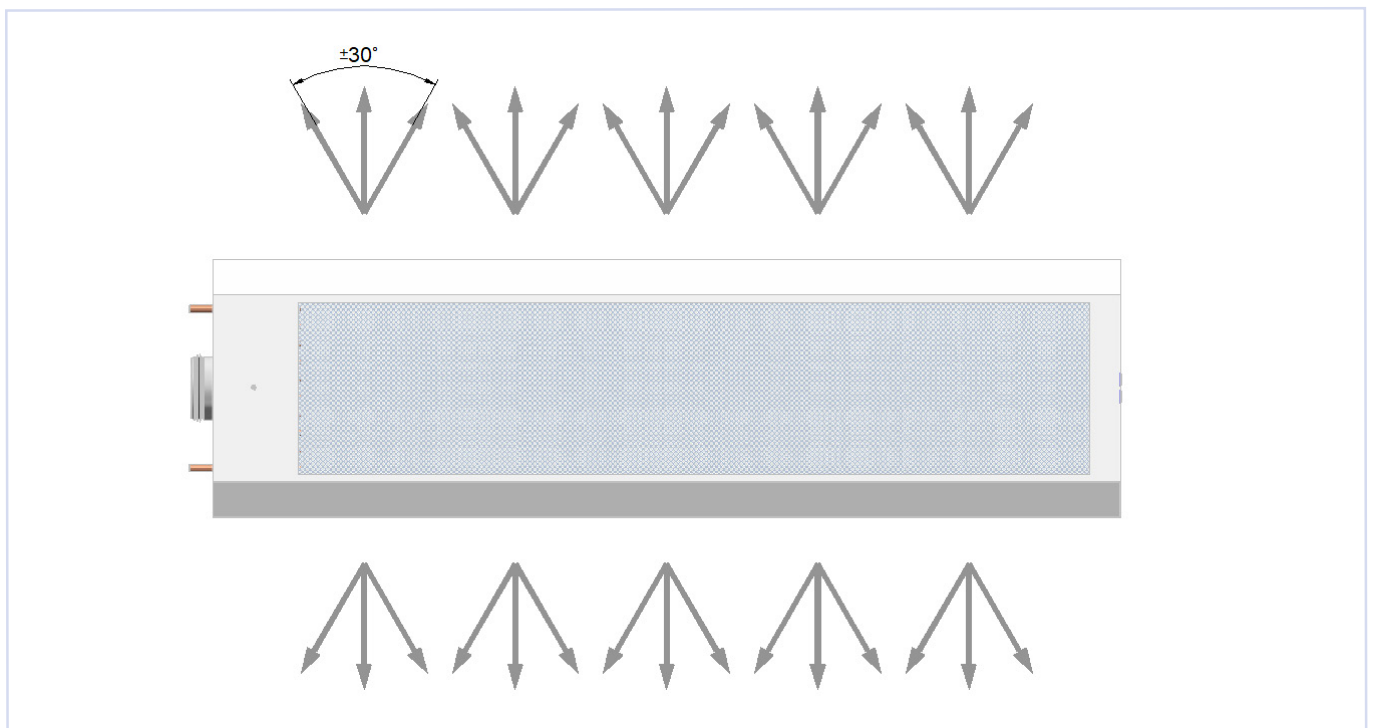

Figure 6, flow pattern

Svalbard-F Comfort

INSTALLATION

Svalbard-F Comfort is supplied with mounting brackets on top of the unit. Covers on each side is removed for easy access to brackets and inspection hatches. See Figure 7. You have possibility of adjustment +/- 25 mm in the baffle length direction, and vertically by means of threaded rod. Use of anchor or similar is recommended when mounting on a concrete base.

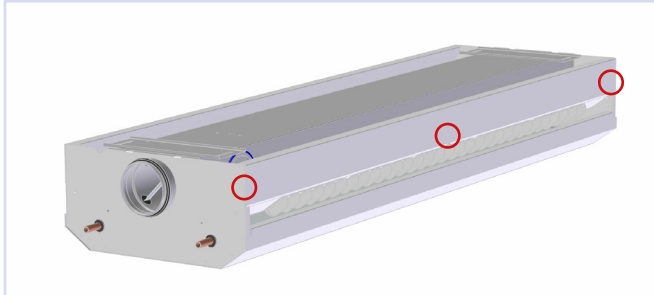

Figure 7, Svalbard-F Comfort, installation, 3 screws must be removed on each side for access to mounting brackets or inspection hatches

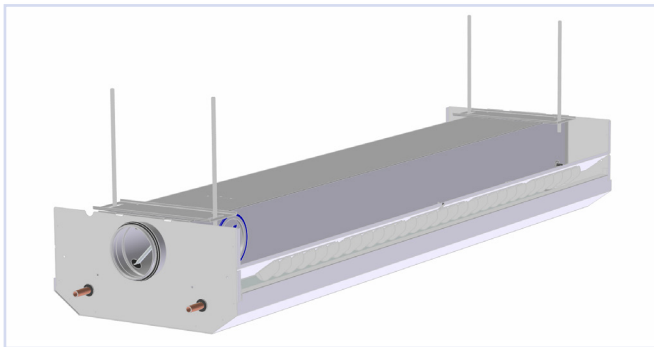

Figure 8, Svalbard-F Comfort, installation

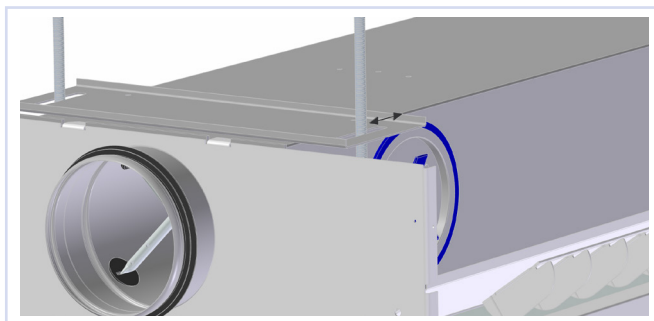

Figure 9, Svalbard-F Comfort, installation

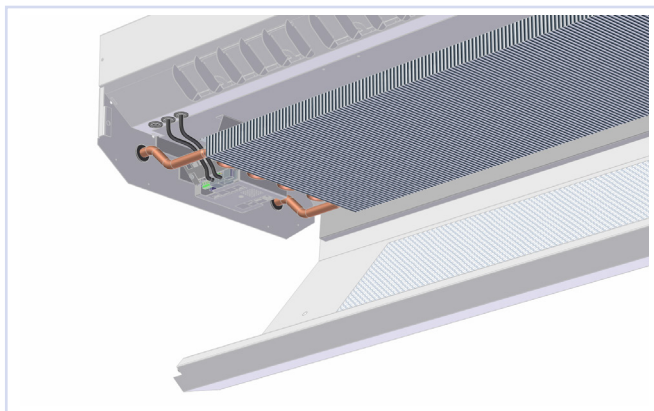

Figure 10, Svalbard-F Comfort, maintenance

INSTALLATION, WATER VALVE

The cooling coil in Svalbard-F Comfort is independent of water flow direction, in/out connection is optional.

COMMISSIONING

Commissioning of Svalbard-F Comfort is easy with TROX-ECA app, which can be downloaded free of charge from Google Play or App Store. TROX-ECA communicate wirelessly by Bluetooth with the controller in Svalbard-F Comfort. Air volume settings, pressure setpoint and Modbus parameters is set easily by the app.

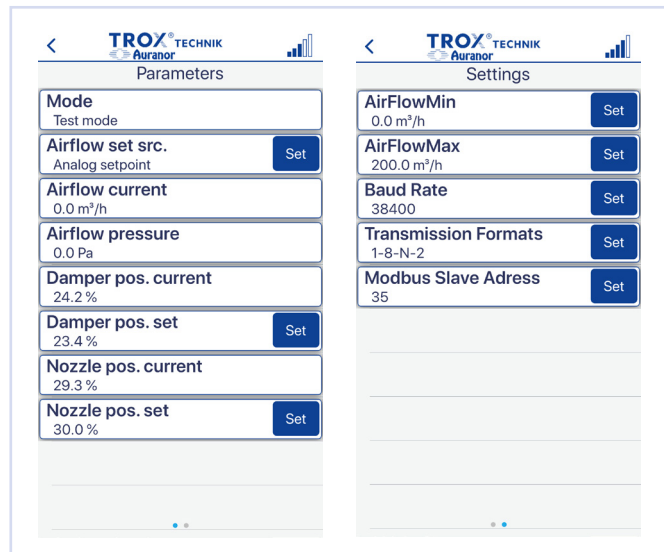

Figure 11, TROX ECA (Easy Commissioning App)

MAINTENANCE

Full access to the coil is achieved by folding down the front panel as shown in fig. 10. Vacuuming and, if required, using a damp cloth to clean the unit is recommended.

ENVIRONMENT

Enquiries regarding product declaration can be directed to our sales team, or information can be found at our website: www.trox.no

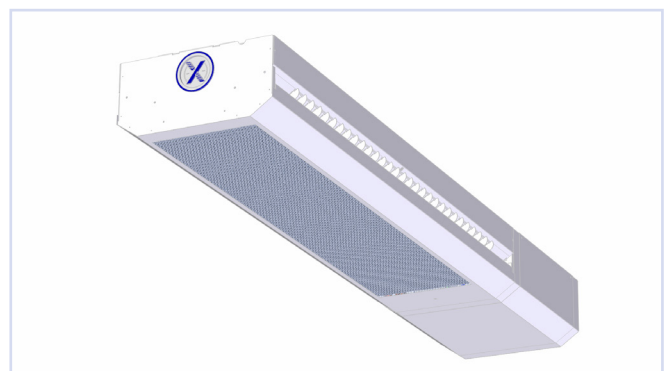
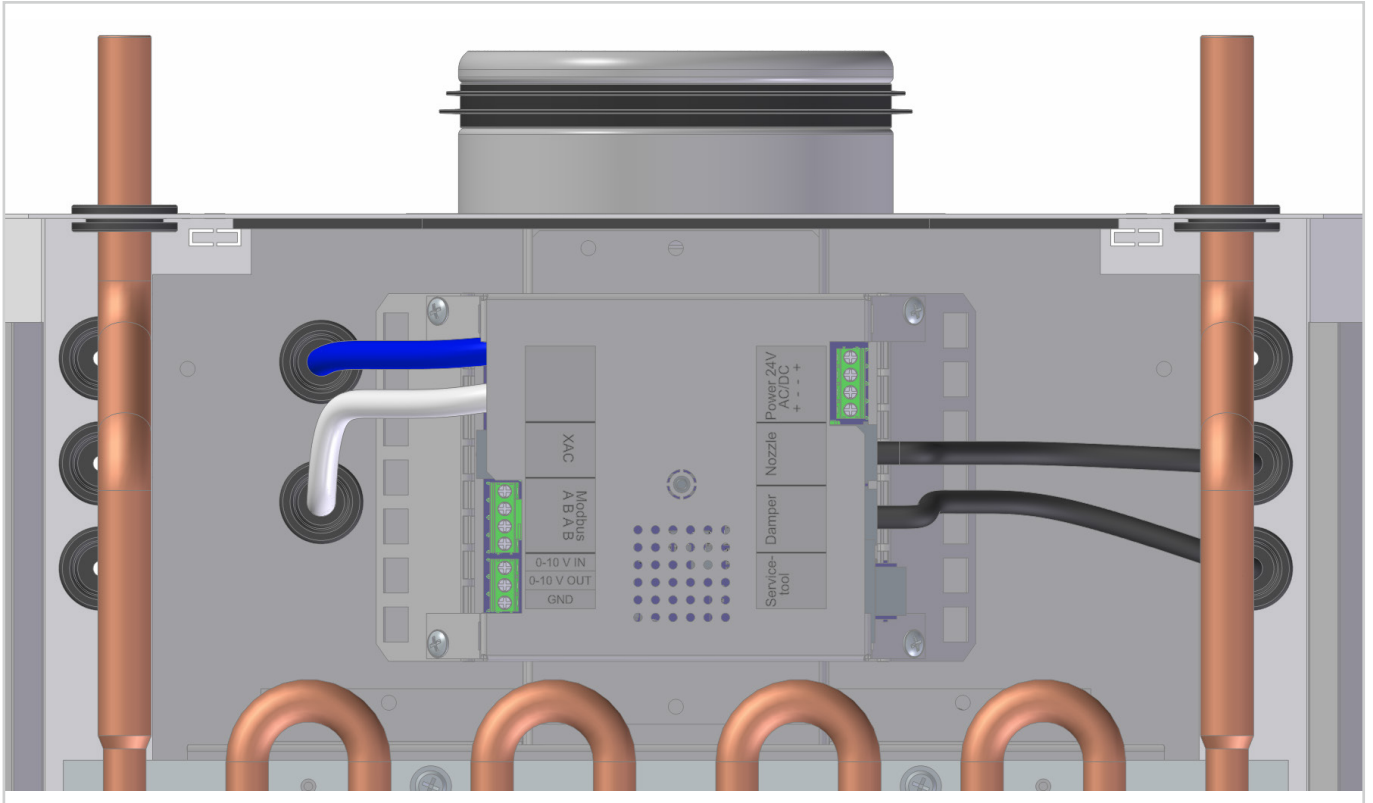

Figure 12. Blind cover. Separate mounting instructions are to be found at www.trox.no

Svalbard-F Comfort



PAIRING SEQUENCE

Make sure the Bluetooth connection is activated on your phone/tablet, and pairing mode is activated. Open the TROX-ECA app, hold the pairing button on the controller inside for 2 sec. App pairing code is 511481.

If the controller needs to be reset, the pairing button is held down for 10 seconds.

Wiring diagram

Power 24V = 24V AC/DC

Nozzle = Connection for nozzle actuator

Damper = Connection for damper actuator

Service tool = Service tool entry

XAC = Input for X-AIRCONTROL

Modbus ABAB = Input and output for modbus line

0-10V in = Input

0-10V out = Output (damper position)

GND = Common 0 for 0-10V