

KAI · ITH · AKH

ROOF HOODS FOR INTAKE AND EXHAUST

- Low-profile design
- Intake and exhaust in the same product (KAI)
- Connection duct as an added feature
- Now with a diagram to aid accurate sizing
- NOTE! New footplate dimensions from 01.01.2023

APPLICATION

KAI is a rectangular roof hood that contains both an intake section and an exhaust section.

ITH is a rectangular intake hood.

AKH is a rectangular exhaust hood.

DESIGN

KAI and ITH both have an aluminium insect net that prevents insects from entering the system, and a self-closing damper in the exhaust section.

The internal drainage system inhibits water ingress. An insulated connection duct can be supplied as an added feature, which has an impermeable bottom plate that allows to connect any duct size. As a

speciality product, KAI can be shipped with a double intake or exhaust hood. The foot plate and connection duct sizing can be customized upon request.

DESCRIPTION

MATERIALS AND SURFACES

KAI, ITH og AKH are all manufactured in galvanised steel. The dampers in KAI and AKH are made out of aluminum. The products can be produced in other materials or be coated upon request. The connection

ducts are produced in galvanised steel and insulated using mineral wool with glass fibre cloth. As Special materials, it can be supplied in copper, stainless steel, acid-resistant steel, or Magnelis.

INSTALLATION



Mounting instructions are displayed in figure 5 and 6. The roof unit and the connection duct are mounted together with the supplied screws

TECHNICAL INFORMATION

Order code, KAI, ITH og AKH

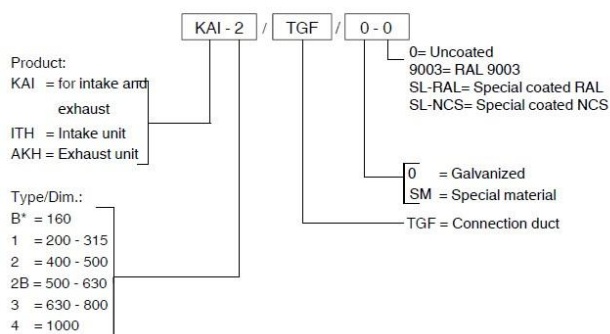

*Type B-Only KAI without TGF

Example:

KAI-2/ TGF /0-0

Explanation:

KAI combo-hat, type 2 for dimension Ø400 - Ø500, connection duct (TGF) is shipped unmounted, galvanized, uncoated



QUICK SELECTION

Type	KAI and ITH (intake) [m ³ /h]		
	20Pa	30Pa	40Pa
B*	612	738	900
1	2880	3258	3960
2	4320	5040	5760
2b	7200	9000	10440
3	10800	13680	15120
4	16200	19800	23400

Table 1: Displays air flow rates in m³/h for intake

Type	KAI og AKH (exhaust) [m ³ /h]		
	50Pa	75Pa	100Pa
B*	504	576	702
1	1476	1836	2124
2	3420	4320	5040
2b	7200	9000	10440
3	10080	12240	14400
4	14760	18000	21600

Table 2: Displays air flow rates in m³/h for exhaust