



Modbus zone module
X-AIR-ZMO-MOD



Antenna, part of the supply
package



Antenna cable, 50 cm, part of
the supply package



Antenna feed-through, part of
the supply package

FAM-RADIODUCT

FOR A RADIO LINK CONNECTION OF TROX X-AIRCONTROL MODULES MAINLY THROUGH THE VENTILATION DUCT

- Patented TROX radio transmission through the ventilation duct
- Wireless data connection of the X-AIRCONTROL zone modules and zone masters up to the air handling unit
- Wireless mesh radio system with frequency hopping
- Plug-and-play connection of the X-AIRCONTROL modules to the RadioDuct ventilation duct radio system
- With integrated repeater function for range extension
- Automatic routing of data via the RadioDuct radio systems available in the system
- Virtually interference-free use due to shielding against external

interference and emitted radio radiation

- Continuous radio link without interference (walls, concrete ceilings) from rooms to the air handling unit

Optional equipment and accessories:

- PC software: configuration software for the commissioning and diagnosis of the RadioDuct module
- RJ12 connection cable for easy plug and play

General information



Application

The RadioDuct duct radio system acts as a wireless data link

- Between X-AIRCONTROL zone modules and the X-AIRCONTROL zone master
- Among the X-AIRCONTROL zone modules

The system is used whenever laying a bus cable for the connection is very difficult or not even possible. The connection variant has advantages compared to conventional bus cables, especially when it comes to refurbishment and retrofitting.

Depending on the characteristics of the channel system, the radio link range may vary. When using several RadioDuct modules in the duct system, the radio connection is continuously optimised via the module's integrated, self-learning mesh function and frequency hopping. These functions find the best radio path through the duct system for the data packets to be transmitted. For longer distances and branched channel systems, mesh repeaters are available that pick up, amplify and forward the radio signals.

Special features

- Up to 30 m cable length between RadioDuct module and X-AIRCONTROL zone module and zone master
- RadioDuct module mountable on the duct or wall
- Antenna connected to the RadioDuct module by cable, allowing easy and free positioning in the duct
- Simple commissioning of the radio connection via guided pairing process
- High operational reliability due to permanent self-monitoring of the communication between RadioDuct module and X-AIRCONTROL system, as well as the radio mesh connection

Parts and characteristics

- Plastic casing mountable to the duct or wall
- Three-colour display of the status of the radio network connection (green, yellow, red)
- Integral service socket for configuration and diagnosis of the RadioDuct module
- Antenna for integration in the duct with 50 cm connection cable and antenna holder for duct installation

Useful additions

- PC software: configuration software for the commissioning and diagnosis of the RadioDuct modules
- Wireless communication possible for configuration with Bluetooth module BlueCON

Construction features

- Casing with removable cover for easy access to internal connections and components
- Easy connection of the X-AIRCONTROL modules through plug-in connections from the outside of the RadioDuct module
- Easy access to the configuration socket from outside of the RadioDuct module

Materials and surfaces

- Casing in ABS plastic, UL-V0
- Casing in blue (RAL 5002)/transparent cover

TEKNISK INFORMASJON

Function, Specification text, Order code



The RadioDuct radio system is used to connect X-AIRCONTROL zone modules to the X-AIRCONTROL zone master via a radio link through ducts. In the process, the X-AIR zone modules can each be equipped with a RadioDuct module as shown in the figure above and send their data to the X-AIR zone master. In addition, the X-AIRCONTROL zone modules in the zone can also be connected in the classical manner by means of a cable. In this case, the first zone module sends the data to the X-AIRCONTROL zone master by radio (see the figure below).

The RadioDuct system uses every other node in the RadioDuct network to get the data to its destination. In contrast to normal networks, the distribution of many nodes throughout the system is even an advantage here. This is because each node in the RadioDuct network forwards the data packets of the other nodes to their destinations. The system independently searches for the best route to the desired recipient. Such networks are known as mesh networks. Furthermore, the required radio power is adapted to the transmission distance. The radio power can assume a maximum value of 100 mW so that the requirements of the applicable radio standards for the 2.4 GHz band are met. To counteract any interference in the frequency band, the RadioDuct module supports automatic frequency hopping. As a result, the respective radio channel with the least interference is selected throughout.

The connection between the RadioDuct slaves and the RadioDuct master is established via a service tool and a simple pairing process mapped therein. The connection and data exchange take place via an encrypted radio channel with 128-bit AES technology. This technology provides high data security and meets the requirements of data protection standards.

Bidirectional data transmission via radio link through ducts

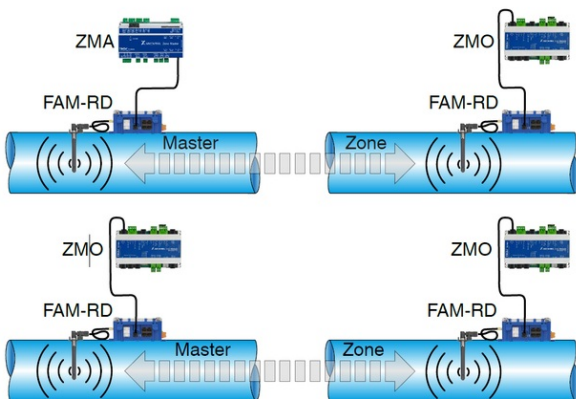

Note: Additional installation examples in the installation and operating manual

Specification text

RadioDuct system for data connection of X-AIRCONTROL zone modules with the X-AIRCONTROL zone master via a radio link in the duct.

Area of application

- Suitable for retrofitting existing systems
- For areas that are difficult to wire

Operating modes

The RadioDuct module supports 3 operating modes that can be set via the software.

- RadioDuct master: manages and organises the RadioDuct network and establishes the connection to the X-AIRCONTROL zone master
- RadioDuct zone: participant in a RadioDuct network and establishes the connection to the X-AIRCONTROL zone modules
- RadioDuct repeater: RadioDuct module for range extension and optimisation of the RadioDuct network

Assembly and installation

- Plastic housing mountable on ventilation duct or wall
- Antenna holder for duct installation included in supply package

Electrical connection

- Plug-in terminals (plug and play) RJ12 socket to the X-AIRCONTROL zone module

Supply voltage

- 24 V AC/DC

System connections

- Simple system connection to X-AIRCONTROL for further processing and evaluation Modbus/BACnet

Parameter settings

- Integration of the RadioDuct modules through step-by-step instructions in the PC software
- Configuration, parameterisation and diagnosis via PC software

Special features

- Self-organising radio data network (mesh) for the use of several RadioDuct modules
- Automatic optimisation of the transmission paths
- Optical LED indicator for the connection and communication status

Factory condition

- Antenna for integration in the duct with 50 cm connection cable
- Antenna holder for duct installation included in the supply package

FAM
|
1

-

X-AIR
|
2

/

D32-RD
|
3

1 Type
FAM Field Application Module

2 Variant
X-AIR X-AIRCONTROL

3 Expansion module
D32-RD RadioDuct

Order example: FAM/X-AIR/D32-RD

Type FAM
Variant X-AIRCONTROL
Expansion module RadioDuct

Technical data, Illustrations, Product details, Installation and commissioning



Supply voltage	24 V AC or DC
Power rating	5 VA
Radio frequency	2.4 Ghz
Maximum radio power	100 mW
Encryption	128 Bit AES
Connection cable X-AIR to RadioDuct	RJ12 plug connection (6P6C) Cable type AWG26/6C Distance up to 30 m
IEC protection class	III (protective extra-low voltage)
Operating temperature	10 - 50 °C
Protection level	IP20
CE conformity	<ul style="list-style-type: none">• EMC Directive 2014/30/EU• EU Radio Equipment Directive RED 2014/53/EU• ROHS 2011/65/EU
Weight	500 g
Dimensions	130 × 130 × 60 mm

Note: Additional technical data in the installation and operating manual

Product details

Application of RadioDuct module on X-AIRCONTROL zone master

Application

The RadioDuct module connected to the X-AIRCONTROL zone master also serves as the master for the RadioDuct mesh network to be set up. The RadioDuct master coordinates the network setup and receives all data from the field from the zone modules with RadioDuct module and transmits it to the associated X-AIRCONTROL zone master. In addition, the RadioDuct system can be used to connect 2 X-AIRCONTROL zone modules with one another via a radio link. For this purpose, one of the two RadioDuct modules must also act as master, preferably the module that is closest to the X-AIRCONTROL zone master in the bus line (Figure 2 on page 3).

In addition, the RadioDuct system can be used to connect 2 X-AIRCONTROL zone modules with one another via a radio link. For this purpose, one of the two RadioDuct modules must also act as master, preferably the module that is closest to the X-AIRCONTROL zone master in the bus line (Figure 2 on page 3).

Functions

- Setting up a RadioDuct mesh radio network with up to 25 nodes
- Encrypted registration of the participants at the RadioDuct master
- Encrypted transmission of data between RadioDuct master and zone
- AES 128-bit encryption

LED function display

The RadioDuct module contains 3 LEDs in the colours red, yellow and green, which indicate the connection and transmission status. Additional information on this can be found in the installation and operating manual.

Application of RadioDuct module on X-AIRCONTROL zone module

Application

The RadioDuct module connected to the X-AIRCONTROL zone module is located in the radio zone. It integrates itself into a RadioDuct network set up by the RadioDuct master. For this, the RadioDuct zone modules must know the network name and network code of the RadioDuct master. The network name and network code are communicated via a simple pairing process using the configuration software.

Functions

- Connecting to a RadioDuct mesh radio network
- Encrypted logon to the RadioDuct Master
- Encrypted transmission of data between RadioDuct master and slave
- AES 128-bit encryption

LED function display

The RadioDuct module contains 3 LEDs in the colours red, yellow and green, which indicate the connection and transmission status. Additional information on this can be found in the installation and operating manual.

Application of RadioDuct module as repeater

Application

The RadioDuct module is integrated into the ventilation duct system as a repeater in order to be able to include longer distances and radio undersupplied parts of the duct system in the RadioDuct network.

Functions

- Connecting to a RadioDuct mesh radio network
- Boosting and forwarding RadioDuct data in the radio network
- Encrypted logon to the RadioDuct master
- Encrypted transmission of data between RadioDuct master and slave
- AES 128-bit encryption

LED function display

The RadioDuct module contains 3 LEDs in the colours red, yellow and green, which indicate the connection and transmission status. Additional information on this can be found in the installation and operating manual.

Installation and commissioning

- Fasten the RadioDuct module to the ventilation duct or wall with 2 screws
- Drill a 10 mm diameter hole in the ventilation duct for the antenna
- Attach the antenna holder to the ventilation duct and insert the antennas
- Screw the antenna cable to the RadioDuct module
- Connect the RadioDuct module to the X-AIR module with the RJ12 cable to be assembled
- Commissioning the RadioDuct module using the configuration software
- Additional connection examples can be found in the installation and operating manual



FAM Module RadioDuct, view 1



- 1: Sensor connections S1, S2, S3 (no function)
 - 2: Antenna connection
- FAM Module RadioDuct, view 2



- 3: CL1 = BUS CC1 communication cable; CL2 = BUS CC2 communication cable (no function)
 - 4: T5 = X-AIRCONTROL connection
 - 5: Push button for activating service port T1
 - 6: T1 = service and multiport; T2 - T4 = multiport (no function)
 - 7: Digital input 1 - 3; analogue input 1; temperature input (no function)
 - 8: Power = connection for supply voltage
 - 9: Digital output DO (NO, C, NC) (no function)
- Supply package for RadioDuct



- 1. Field Application Module (FAM) with RadioDuct extension board
- 2. Antenna
- 3. Antenna feed-through with drilling screws for duct

4. Antenna cable, length 50 cm