

Multileaf Dampers

- Type JZ · JNE
- Type JZ-L and JZD-G
(low leakage to the requirements of DIN 1946)



TROX[®] TECHNİK

• TROX GmbH
• Heinrich-Trox-Platz
• D-47504 Neukirchen-Vluyn

Telephone +49/28 45/2 02-0
Telefax +49/28 45/2 02-2 65
e-mail trox@trox.de
www.troxtechnik.com

Contents · Description

Description _____	2	Product range _____	10
Constructions _____	3	Technical data _____	14
Installation details _____	7	Order details _____	19
Standard sizes · Flange drilling details _____	9		

JZ-A



JZ-B



Multileaf dampers are primarily used in ventilation systems for volume flow and pressure control. **In addition, the type JZ-L and JZD-G satisfied the closed blade leakage requirements specified in DIN 1946 (leakage <math>< 10 \text{ m}^3/\text{h} \cdot \text{m}^2</math> of damper cross-section with a 100 Pa pressure differential).**

The aerofoil section blades are coupled by external linkage, which can provide either parallel or opposed blade operation, or in the case of type JZ-G and JZD-G, opposed blade action only, via gears.

The type JNE damper is entirely constructed from stainless steel and is suitable for applications where a high level of corrosion resistance is required.

The damper has to be installed with horizontal blades.

JZ-G

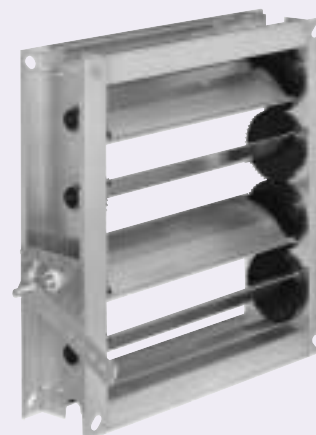

Type JZ-A · JNE-A

JZ-A

- Casing and blades made from galvanised rolled sheet steel, casing flanges with holes in the corners on both sides
- Blade spindles and external linkage made from galvanised steel
- Plain bearings made from special plastic
- Parallel blade operation
- Drive arm may be located on any blade
- Temperature resistant to 100 °C

JNE-A

- Casing, blade spindles and external linkage made from stainless steel, DIN ref. 1.4301, casing flanges with holes in the corners on both sides
- Plain bearings made from special plastic
- Parallel blade operation
- Drive arm may be located on any blade
- Temperature resistant to 100 °C

- ① Casing
- ② Blade
- ③ Drive arm (x dimension, see page 9)
- ④ External linkage

Type JZ-A · JNE-A

Standard sizes

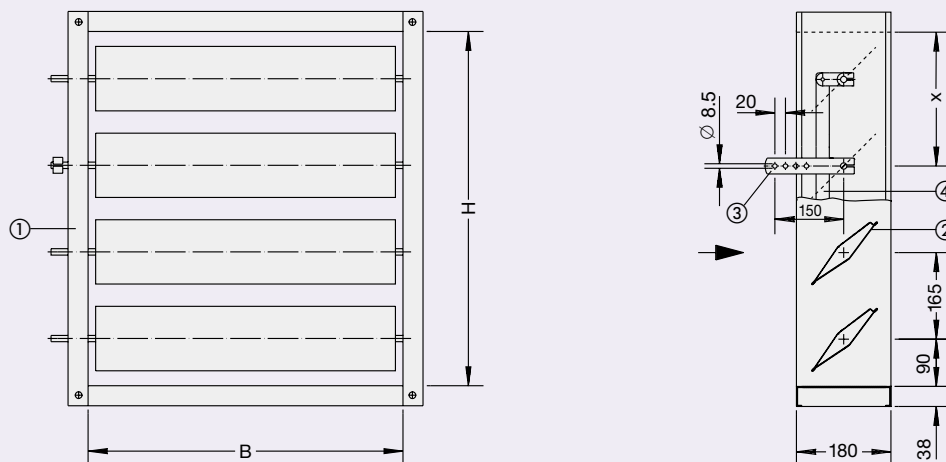

Type JZ-A

R20 sizes

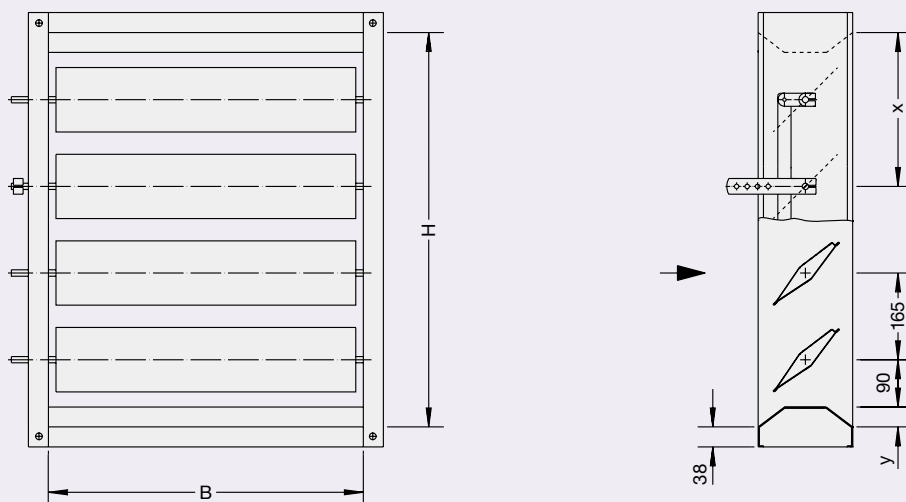

Right hand drive "R" shown when viewed in the direction of the arrow

$y = 1.5$ to 81.5 mm (depending on the H dimension)

Construction

Type JZ-B · JZD-B · JNE-B

JZ-B

- Casing and blades made from galvanised, rolled sheet steel, casing flanges with holes in the corners on both sides
- Blade spindles and external linkage made from galvanised steel
- Plain bearings made from special plastic
- Opposed blade action
- Drive arm may be located on any blade
- Temperature resistant to 100 °C

JNE-B

- Casing blades, blade spindles and external linkage made from stainless steel, DIN ref. 1.4301, casing flanges with holes in the corners on both sides
- Plain bearings made from special plastic
- Opposed blade action
- Drive arm may be located on any blade
- Temperature resistant to 100 °C

JZD-B

Same as type JZ-B, except:

- Also with blade tip seals
- Temperature resistant to 90 °C

Type JZ-B · JZD-B · JNE-B

Standard sizes

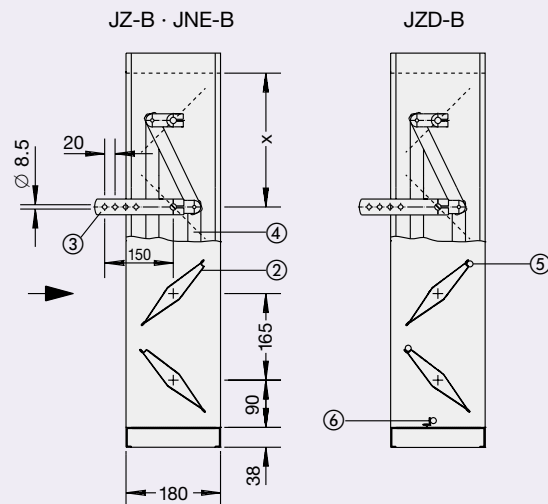
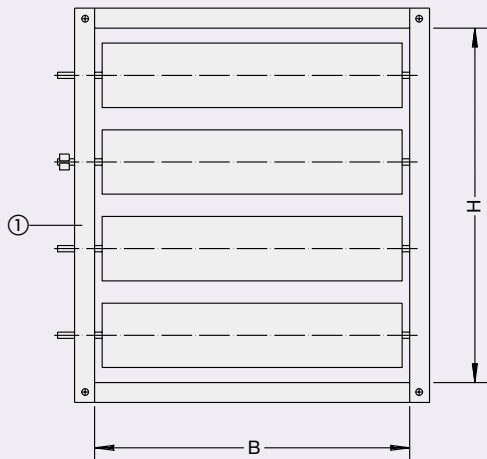

Type JZ-B · JZD-B

R20 sizes

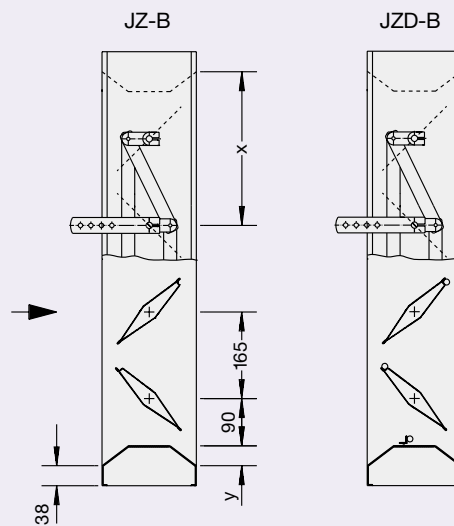
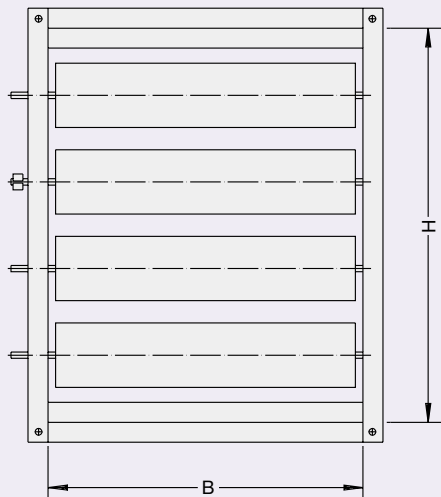

Right hand drive "R" shown when viewed in the direction of the arrow $y = 1.5$ to 81.5 mm (depending on the H dimension)

Type JZ-L (low leakage to DIN 1946)

- Casing and blades made from galvanised rolled sheet steel, casing flanges with holes in the corners on both sides
- Blade spindles and external linkage made from galvanised steel
- Plain bearings made from special plastic
- Blade tip seals made from special plastic; side seals made from foam material
- Opposed blade action
- Drive arm may be located on any 2nd blade
- Temperature resistant to 90°C

- ① Casing
- ② Blade
- ③ Drive arm (x dimension, see page 9)
- ④ External linkage
- ⑤ Tip seals
- ⑥ Landing angle (full width of the B dimension)
- ⑦ Side seal/sliding disc

Type JZ-L Standard sizes

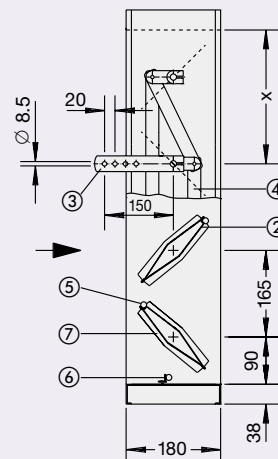
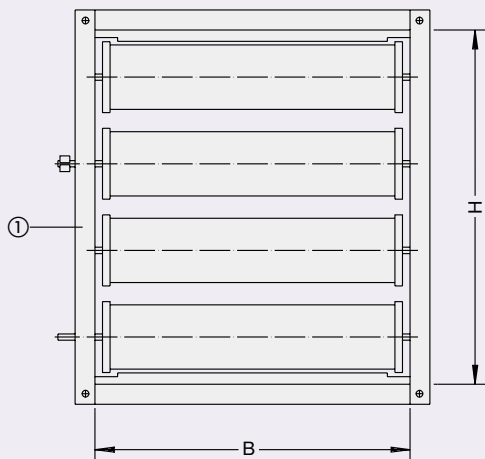

Type JZ-L R20 sizes

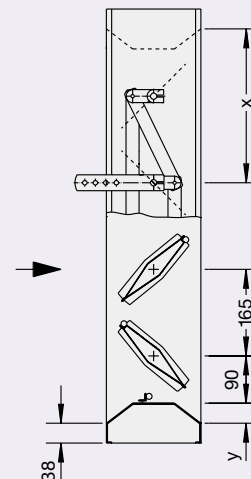
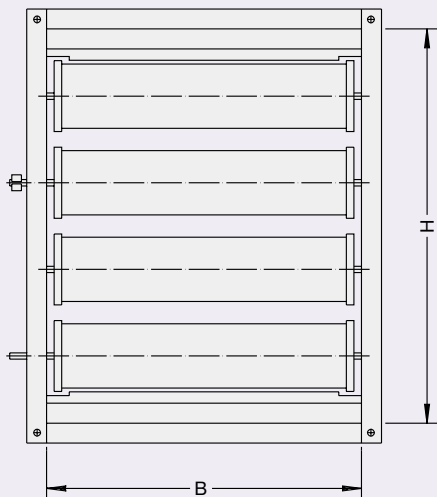

Right hand drive "R" shown when viewed in the direction of the arrow

y = 1.5 to 81.5 mm (depending on the H dimension)

Construction

Type JZ-G · JZD-G

JZ-G

- Case and blades made from aluminium extruded sections, case flanges with holes in the corners on both sides
- Blade spindles made from galvanised steel
- Gears made from special anti-static plastic
- Galvanised steel drive arm
- Blades inter-connected by gears located at each end of the blade
- Temperature resistant to 90 °C

- ① Casing
- ② Blade
- ③ Drive arm (x dimension, see page 9)
- ④ Tip seal
- ⑤ Gear
- ⑥ Bearing detail
- ⑦ Locking quadrant and position indicator with movement between OPEN/CLOSED (standard for type JZD-G)

JZD-G (low leakage to DIN 1946)

- Case and blades made from aluminium extruded sections, case flanges with holes in the corners on both sides
- Blade spindles (from H = 800 mm, 2 sections with coupling rods) made from galvanised steel
- Gears made from special anti-static plastic
- Drive arm, locking quadrant and position indicator made from galvanised steel
- Seals on the long blade sides and bearings made from special plastic
- Blades interconnected by internal gears
- Temperature resistant to 70 °C

Type JZ-G

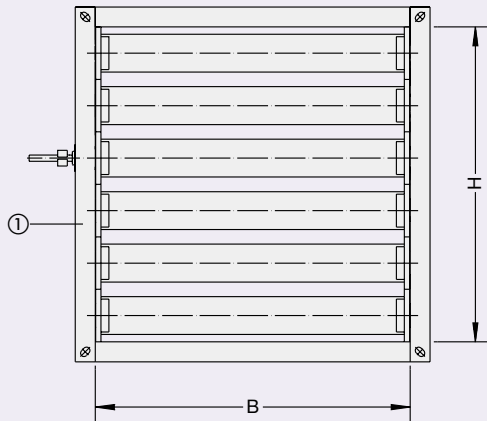

H = 100 / 200 – 1000

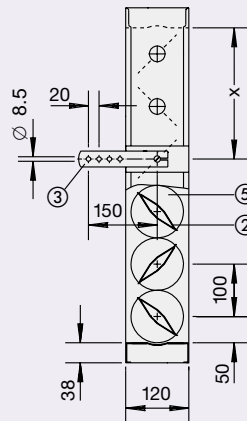

H = 150 / 250 – 950

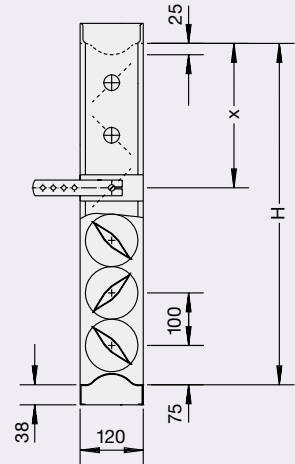

Type JZD-G

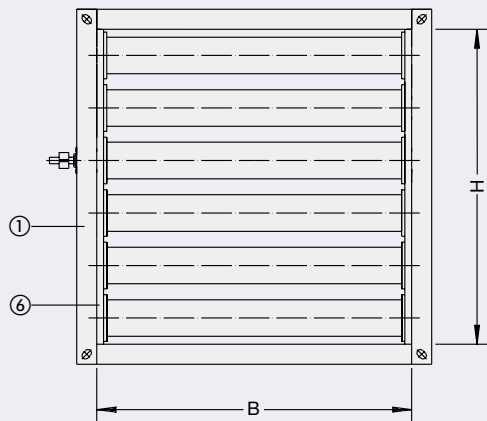

H = 100 / 200 – 1000

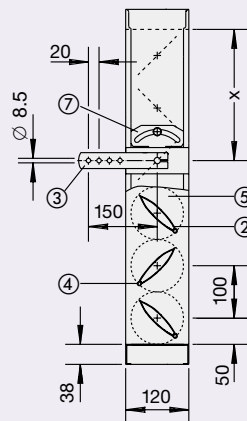

H = 150 / 250 – 950

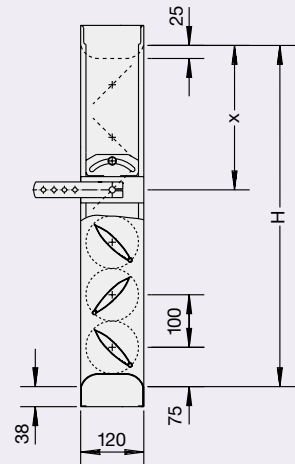

Type JZ-A · JZ-B · JZD-B · JZ-L · JZ-G · JZD-G

Masonry subframe supply schedule:
Galvanised steel masonry subframe;
Screw-on builders cleats, special studs, screws, nuts and washers made from galvanised steel.

Masonry subframe fitted to the multileaf damper, builders cleats fitted by others.

Type JNE-A · JNE-B

Masonry subframe supply schedule:
Stainless steel masonry subframe with welded builders cleats
nuts and washers in stainless steel.

Type JZ-A · JNE-A · JZ-B · JZD-B · JNE-B · JZ-L

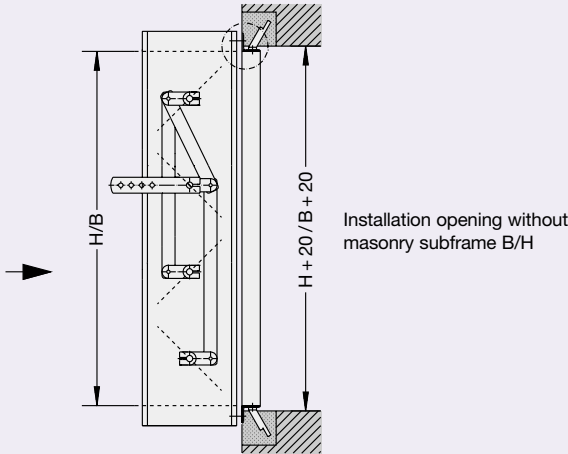

Type JZ-B shown
Right hand drive "R" when viewed in the direction of the arrow

Details of masonry subframe

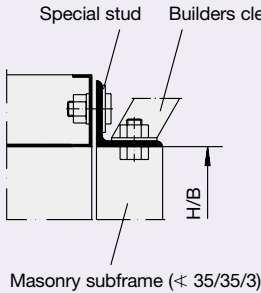

Type JZ-G · JZD-G

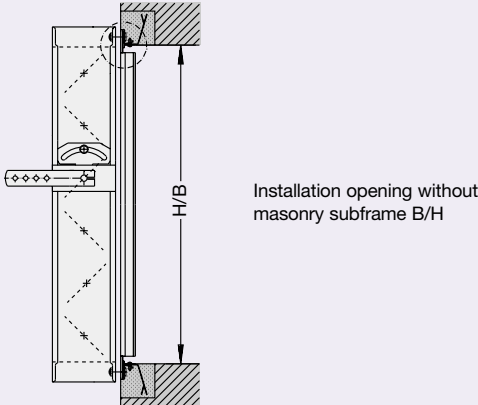

Type JZD-G shown

Details of masonry subframe

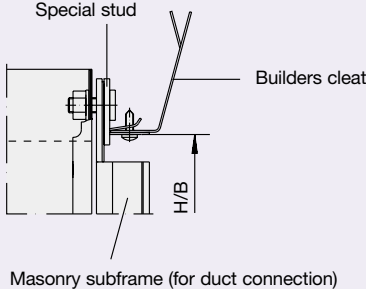

Installation Details

Type JZ-A · JZ-B · JZD-B · JZ-L

If the B dimension is greater than 2000 mm or the H dimension greater than 1995 mm, 2 dampers can be provided for installation side by side or one above the other.

They may be installed either with or without a masonry sub-frame.

- Configuration 1 The actuator is fitted by others on site.
Mounting on the damper face using the flanges.
Mounting can be above or below the drive arm.
- Configuration 2 For executions with standard accessories
(e.g. when using spring return actuators).

Type JZ-A · JZ-B · JZD-B · JZ-L

Subdivided on B dimension ($B_1 = 2 B + 150$)

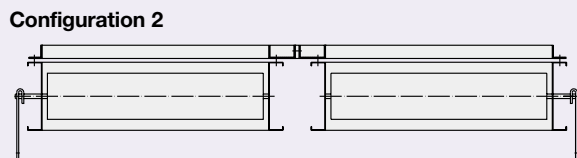
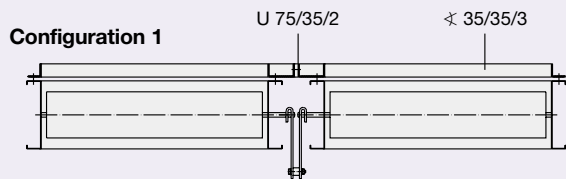
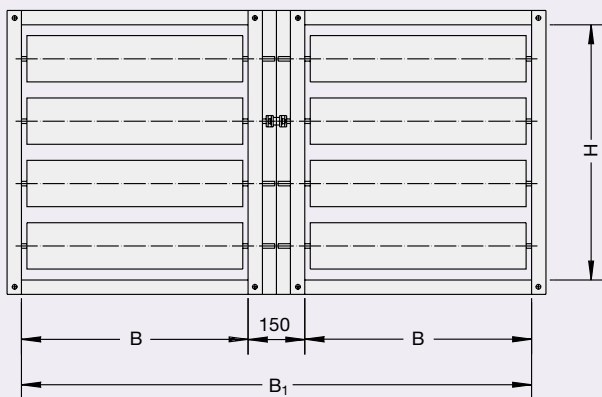

Special masonry subframe
subdivided on B dimension

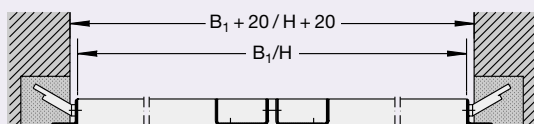

Installation opening with masonry subframe B_1/H

Subdivided on H dimension ($H_1 = 2 H + 76$)

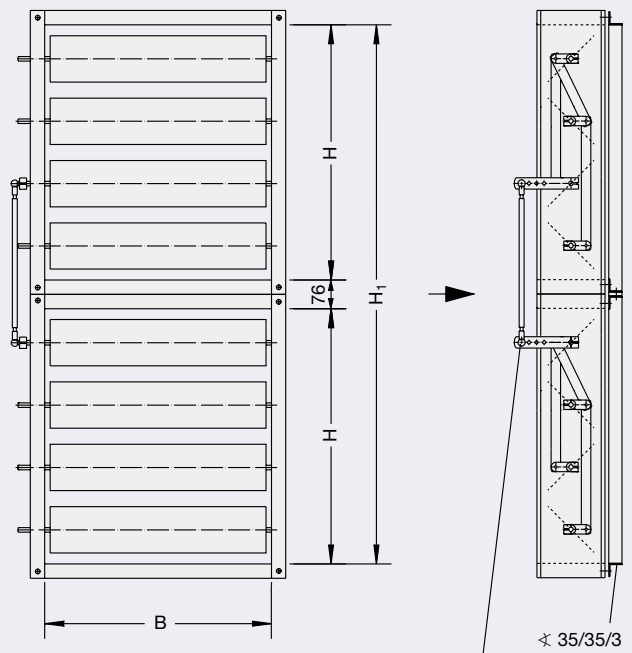

Type JZ-B shown
Right hand drive "R" when viewed in the direction of the arrow

Special masonry subframe
subdivided on H dimension (shown rotated through 90°)

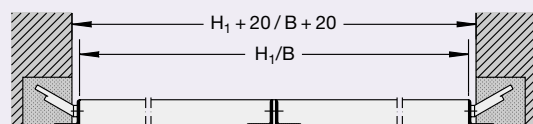

Installation opening without masonry subframe H_1/B

Standard Sizes · Flange Drilling Details

Corner hole layout ¹⁾

Type JZ-A · JNE-A · JZ-B · JZD-B · JNE-B · JZ-L

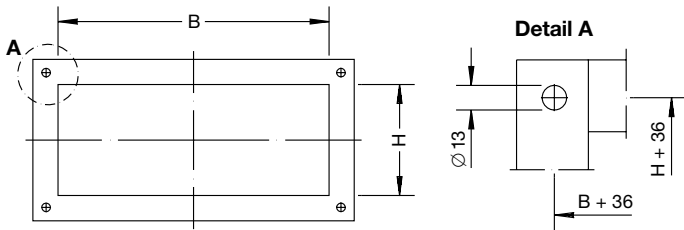

Flange drilling details ¹⁾

Type JZ-A · JNE-A · JZ-B · JZD-B · JNE-B · JZ-L

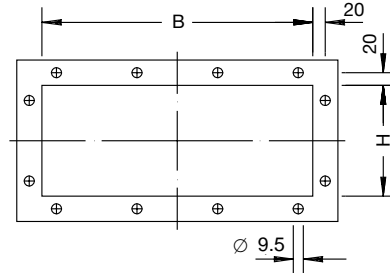

Even number of holes
(hole pitch = 125 mm)

Corner hole layout, Type JZ-G · JZD-G

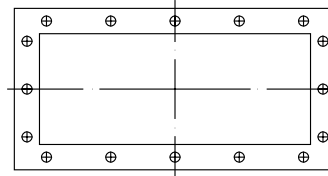
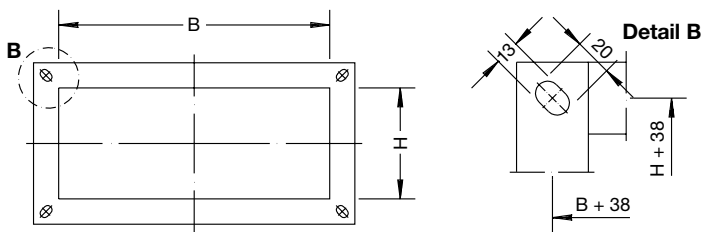

Odd number of holes
(hole pitch = 125 mm)

Type JZ-A · JNE-A · JZ-B · JZD-B · JNE-B · JZ-L Standard sizes

B in mm	H in mm	No. of blades	Position of drive arm x in mm ²⁾	No. of holes per B dim.	H dim.
400	345	2	90	4	4
600	510	3	90	5	5
800	675	4	255	7	6
1000	840	5	420	8	8
1200	1005	6	420	10	9
1400	1170	7	585	12	10
1600	1335	8	585	13	12
1800	1500	9	750	15	13
2000	1665	10	750	16	14
	1830	11	915		16
	1995	12	915		17

Free area = B x H - (31 x B x number of blades)

Type JZ-A · JZ-B · JZD-B · JZ-L Subdivided on B or H dimension

B ₁ in mm	H in mm	H ₁ in mm	B in mm
2550	345	2086	400
2950	510	2416	600
3350	675	2746	800
3750	840	3076	1000
4150	1005	3406	1200
	1170	3736	1400
	1335	4066	1600
	1500		1800
	1665		2000
	1830		
	1995		

Number of blades,
position of drive arm
and number of holes
as per the damper
module size.

All combinations of B,
B₁ and H, H₁ can be
supplied.

Type JZ-A · JZ-B · JZD-B · JZ-L R20 sizes

B in mm	H in mm	No. of blades	Position of drive arm x in mm ²⁾	No. of holes per B dim.	H dim.
357	357	2	96	3	4
400	400	2	118	4	4
449	449	2	142	4	4
503	503 ³⁾	2	169	4	5
565	565	3	118	5	5
634	634	3	152	5	6
711	711	4	273	6	6
797	797	4	316	7	7
894	894	5	447	7	8
1003	1003	6	502	8	9
1125	1125	6	480	9	10
1262	1262	7	631	10	11
1416	1416	8	626	12	12
1588	1588	9	794	13	13
1781	1781	10	808	15	15
1998	1998	12	917	16	17

Free area = next smallest H dimension in the standard sizes - (31 x B x number of blades)

Type JZ-G · JZD-G

B in mm	H in mm	No. of blades	Position of drive arm x in mm	No. of holes per B dim.	H dim.
200	100	1	50 (75)		
250	(150)	1			
300	200	2			
350	(250)	2			
400	300	3			
450	(350)	3			
500	400	4			
550	(450)	4			
600	500	5			
650	(550)	5			
700	600	6	250 (275)		
750	(650)	6			
800	700	7			
850	(750)	7			
900	800	8			
950	(850)	8			
1000	900	9			
	(950)	9			
	1000	10			

Free area = [(B - 25) x H] - [19 x (B - 25) x number of blades]

1) Where flange holes are used (see tables for number), the standard corner holes are dispensed with.

2) Drive arm position for type JZ-L as delivered on the 2nd blade (irrespective of size).

3) Note at H = 503 mm the case construction results in a substantial reduction in the free area.
To avoid this use of H = 510 mm is recommended.

Product Range

Type · Construction variants			
Construction variant abbreviation	Type		
	JZ-A JZ-B JZD-B ⁴⁾ JZ-L	JNE-A JNE-B	JZ-G JZD-G
-G	●	●	
-M	●		
-G-M	●		
-BM	●		
-G-BM	●		
-M-BM	●		
-G-M-BM	●		
-HM	●		
-G-HM	●		
-M-HM	●		
-G-M-HM	●		

- G = Casing both flanges drilled
- M = With brass bearings
- G-M = Casing both flanges drilled and brass bearings
- BM = Subdivided on B dimension
- G-BM = Casing both flanges drilled and subdivided on B dimension
- M-BM = With brass bearings and subdivided on B dimension
- G-M-BM = Casing with both flanges drilled, with brass bearing bushes and subdivided on B dimension
- HM = Subdivided on H dimension
- G-HM = Casing both flanges drilled and subdivided on H dimension
- M-HM = With brass bearings and subdivided on H dimension
- G-M-HM = Casing both flanges drilled, with brass bearings and subdivided on H dimension

4) These types are also available with reinforced blades. In this case, -V must be added after the type code in the order (e.g. JZ-A-M-V).

Accessories

Type or construction variants combined with	Code	Type			
		JZ-A JZ-B JZD-B JZ-L	JNE-A JNE-B	JZ-G JZD-G	
Basic construction		-	-	-	
Limit switch Limit switch indicates damper "CLOSED"	Z01	●	●	-	
Limit switch indicates damper "OPEN"	Z02	●	●	-	
Limit switch indicates damper "CLOSED" and "OPEN"	Z03	●	●	-	
Locking device, see figs. 1.1 and 1.2	Z04	●	●	● ⁷⁾	
Hand locking quadrant and: Limit switch indicates damper "CLOSED"	Z05	●	●	●	
Limit switch indicates damper "OPEN"	Z06	●	●	●	
Limit switch indicates damper "CLOSED" and "OPEN"	Z07	●	●	●	
Spring return electric actuator (power off to close) see figs. 2.1 and 2.2 Damper "CLOSED" when no current					
<p>Note: Connection 24 V by safety transformer</p> <p>Z08 · Z09: an isolation device is required for disconnecting from circuit (min. 3 mm contact break).</p>					
	Z09 · Z11				
	Z08 · Z10				
- Without integral limit switches U = AC 230 V, 50...60 Hz / opening P ≈ 6.5 W / in the open position P ≈ 2.5 W / capacity 11 VA / protective system II / IP54 / opening approx. 150 s / closing approx. 16 s Torque approx. 15 Nm	5)	Z08	●	●	●
- With integral limit switches U = AC 230 V, 50...60 Hz / opening P ≈ 6.5 W / in the open position P ≈ 2.5 W / capacity 11 VA / protective system II / IP54 / opening approx. 150 s / closing approx. 16 s / auxiliary switch: 2 x EPU 6 (3) A, AC 250 V □ Torque approx. 15 Nm	5)	Z09	●	●	●
- Without integral limit switches U = AC 24 V, 50...60 Hz or DC 24 V / opening P ≈ 5 W / in the open position P ≈ 1.5 W / capacity 10 VA / protective system III / IP54 / opening approx. 150 s / closing approx. 16 s Torque approx. 15 Nm	5)	Z10	●	●	●
- With integral limit switches U = AC 24 V, 50...60 Hz or DC 24 V / opening P ≈ 5 W / in the open position P ≈ 1.5 W / capacity 10 VA / protective system III / IP54 / opening approx. 150 s / closing approx. 16 s / auxiliary switch: 2 x EPU 6 (3) A, AC 250 V □ Torque approx. 15 Nm	5)	Z11	●	●	●

Accessories

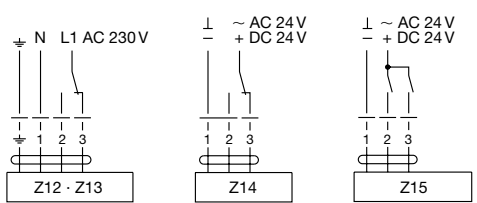
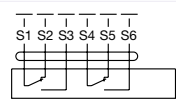
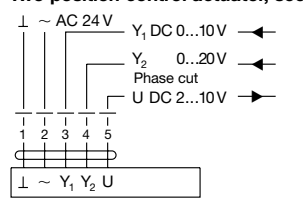
Type or construction variants combined with	Code	Type		
		JZ-A JZ-B JZD-B JZ-L	JNE-A JNE-B	JZ-G JZD-G
Two position actuator reversible open-shut, see fig. 2.1  <p>Note: Connection 24 V by safety transformer Z12 · Z13: an isolation device is required for disconnecting from circuit (min. 3 mm contact break).</p>				
– U = AC 230 V, 50...60 Hz / P = 13...14 W / capacity 13...14 VA / protective system I / IP54 / running time approx. 80 s Torque approx. 15 Nm	6) Z12	●	●	●
– U = AC 230 V, 50...60 Hz / P = 10...13 W / capacity 10...13 VA / protective system I / IP54 / running time approx. 180 s Torque approx. 30 Nm	Z13	●	●	
– U = AC 24 V, 50...60 Hz or DC 24 V / P = 1.8 W / capacity 4 VA / protective system III / IP54 / running time approx. 90...150 s Torque approx. 15 Nm	6) Z14	●	●	●
– U = AC 24 V, 50...60 Hz or DC 24 V / P = 1...3 W / capacity 6 VA / protective system III / IP54 / running time approx. 135 s Torque approx. 30 Nm	Z15	●	●	
Two position actuator Z12 and installed auxiliary switch Two position actuator Z13 and installed auxiliary switch Two position actuator Z14 and installed auxiliary switch Two position actuator Z15 and installed auxiliary switch				
 <p>– 2 x EPU / 6 A (2.5 A) AC 250 V / protective system II / IP 54</p>	Z16	●	●	●
	Z17	●	●	
	Z18	●	●	●
	Z19	●	●	
Two position control actuator, see fig. 2.1  <p>Note: connection by safety transformer</p>				
– U = AC 24 V, 50...60 Hz / P = 3 W / capacity 5 VA / protective system III / IP54 / running time approx: 100...200 s Torque approx. 15 Nm	6) Z20	●	●	●
– U = AC 24 V, 50...60 Hz / P = 2...3 W / capacity 7 VA / protective system III / IP54 / running time approx: 135 s Torque approx. 30 Nm	Z21	●	●	

Ancillaries

Type or construction variants combined with	Type code		
	JZ-A-G JZ-B-G JZD-B-G JZ-L-G	JNE-A-G JNE-B-G	JZ-G JZD-G
One masonry subframe	22	28	33
One masonry subframe (subdivided on B dimension)	26		
One masonry subframe (subdivided on H dimension)	27		

Important!

- 5) Performance data for single actuator. The number of actuators depends on the type and size (see page 13)
- 6) In the case of type JZ-L, only suitable for use up to the sizes indicated in the table on page 13
- 7) In the case of type JZD-G the locking quadrant is supplied as standard on the basic construction

Dampers JZ-A-... and JZ-B-... can also be combined with weather resistant louvres (see leaflet No 3/4/EN/...)

- On request: – in seismic qualified construction
 – in explosion proof construction
 – constructed to accept teleflex drive by others

Finishes available:

P1 = Powder-coated to RAL 9010, RAL 9001, RAL 9002, RAL 9003, RAL 9005, RAL 9006, RAL 9016, RAL 7001, RAL 7035
 S3 = Anodised to Euras standard E6-C-0

Product Range

Configuration – Hand locking quadrant details

Fig. 1.1 Type JZ-A · JNE-A · JZ-B · JZD-B · JNE-B · JZ-L

Fig. 1.2 Type JZ-G · JZD-G

Configuration – Electric actuator details

Fig. 2.1 One electrical actuator

Fig. 2.2 Two electrical actuators

- ⑩ Hand locking quadrant
- ⑪ Locking quadrant and position indicator with movement between OPEN/CLOSED (standard for type JZD-G)
- ⑫ Blade spindle, dia. 12 mm, with groove to indicate the blade position
- ⑬ Spring return actuator

Right hand drive “R” shown when viewed in the direction of the arrow

Fig. 1.1

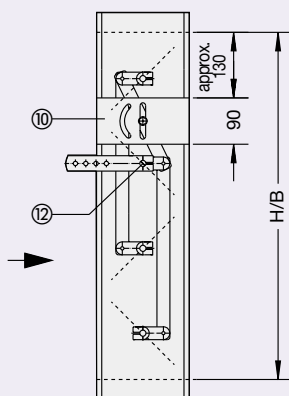

Type JZ-B shown

Fig. 2.1

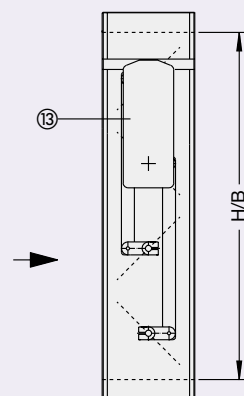
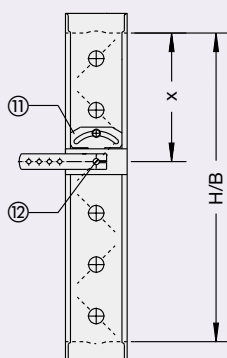
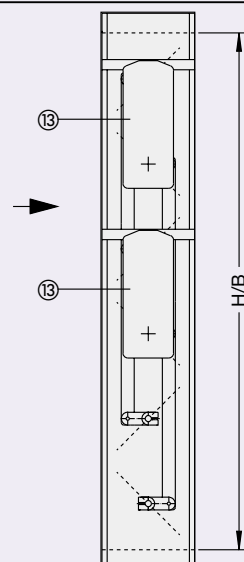

Fig. 1.2



Type JZ-G shown
for x dimension, see page 9

Fig. 2.2



Electrical actuators

Required number of actuators (without taking account of aerodynamic influences) for type:

- JZ-A · JNE-A · JZ-B · JZD-B · JNE-B · JZ-G · JZD-G
one actuator (irrespective of size)
- JZ-L, as per table

Actuators		
Type of actuator	Number up to 15 Nm	Number > 15 Nm
Electric spring return actuator (torque approx. 15 Nm), e.g. Z08	1 piece	2 pieces
Rotary electric actuator, reversible open/closed or modulating (torque approx. 15 Nm), e.g. Z20	1 piece	-
Rotary electric actuator, reversible open/closed or modulating (torque approx. 30 Nm), e.g. Z21	-	1 piece

Type JZ-L											
B in mm	H in mm										
	345 to 509	510 to 674	675 to 839	840 to 1004	1005 to 1169	1170 to 1334	1335 to 1499	1500 to 1664	1665 to 1829	1830 to 1994	1995 to 2000
357 to 400											
401 to 634		8 Nm ⁸⁾			11 Nm ⁸⁾		15 Nm ⁸⁾		20 Nm ⁸⁾		
635 to 800											
801 to 1003										25 Nm ⁸⁾	
1004 to 1262											
1263 to 1416											
1417 to 1600										30 Nm ⁸⁾	
1601 to 2000											

8) Minimum torque M_2 required on factory check to achieve closed blade leakage results in accordance with DIN 1946 (Leakage $< 10 \text{ m}^3/\text{h} \cdot \text{m}^2$ blades closed against pressure difference of 100 Pa) without taking account of aerodynamic influences.

Technical Data

Nomenclature

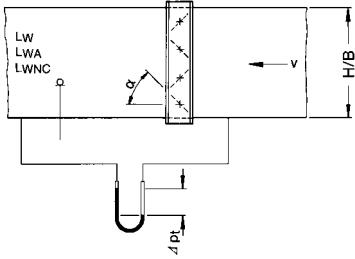

- B in mm: Width
 H in mm: Height
 A in m²: Cross-sectional area (B x H)
 \dot{V} in l/s: Leakage volume flow with blades closed
 \dot{V} in m³/h: Leakage volume flow with blades closed
 v in m/s: Face velocity based on A
 Δp_t in Pa: Total pressure drop (installation type A)⁹⁾
 $\Delta p_{t 0^\circ} \approx 0.7 \cdot \Delta p_{t 10^\circ}$
 α : Blade angle, $\alpha < 10^\circ$ blades fully open

- $L_W = L_{W0} + K$ in dB/oct: Octave band sound power level based on A (re 10⁻¹² W)
 L_{W0} in dB/oct: As above, but based on A = 1.0 m²
 $L_{WA} = L_{WAO} + K$ in dB(A): A-weighted sound power level based on A¹⁰⁾
 L_{WAO} in dB(A): As above, but based on A = 1.0 m²
 $L_{WNC} = L_{WNCO} + K$: NC rating of sound power level based on A
 L_{WNCO} : As above, but based on A = 1.0 m²
 K : Correction factor to octave levels dB(A) or NC ratings for variation in cross sectional area from a reference value of 1.0 m²
 f in Hz: Octave band centre frequency
 ζ : Pressure loss coefficient⁹⁾
 F : Correction factor for $\alpha = 10^\circ$ to 80°
 F_1 : Correction factor (Type JZD-G) for the determination of the pressure drop (installation type A)
 K_1 in dB: Correction factor for calculation of sound power level for type JZD-G

Sound power level and pressure drop $\alpha = 10^\circ$ to 80°

1 Type JZ-A · JNE-A

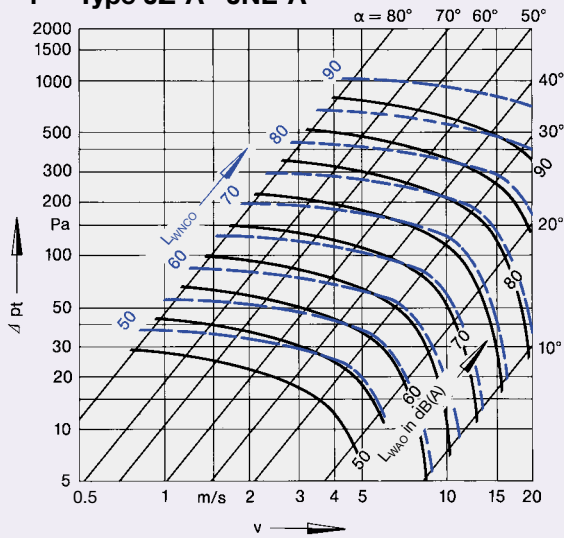

2 Type JZ-B · JZD-B · JNE-B

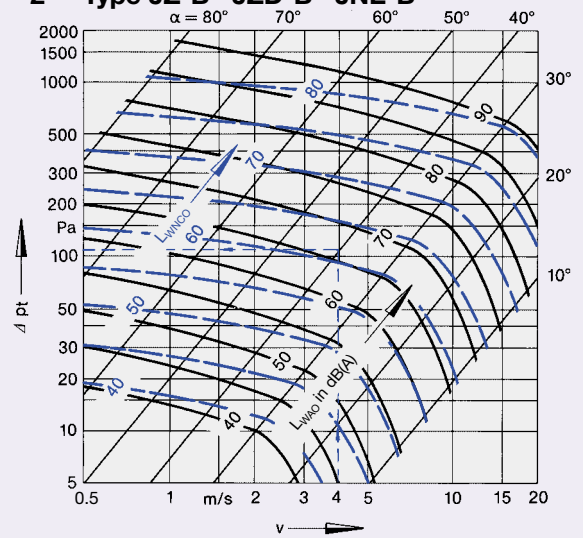

3 Type JZ-L

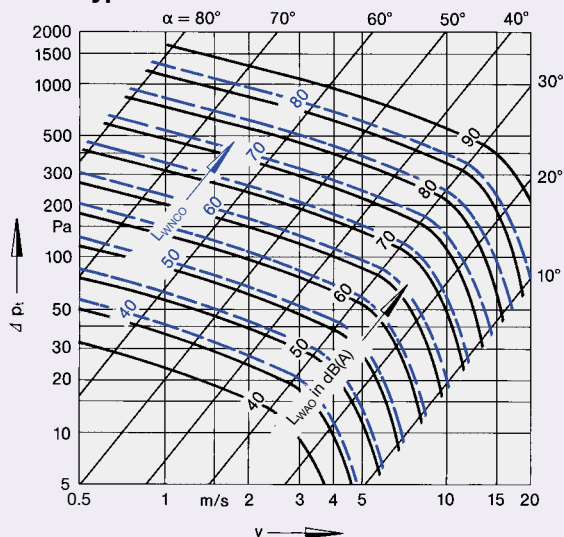

4 Type JZ-G · JZD-G¹¹⁾

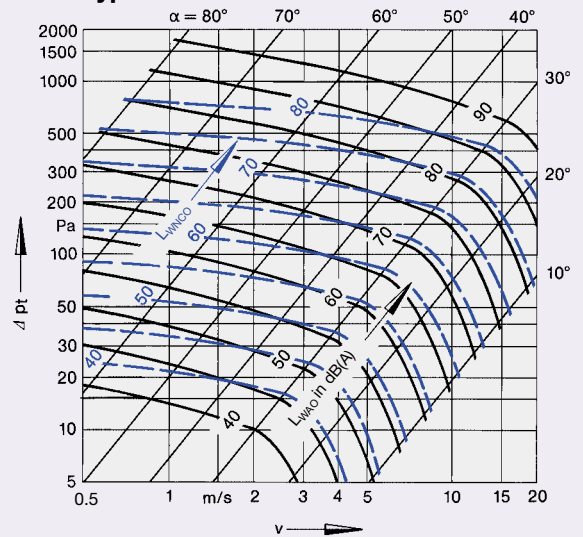

- 9) The pressure loss coefficients ζ according to diagram 10 and the total pressure drop Δp_t shown in diagrams 1 to 4 are based on installation type A (with fully ducted entry and discharge).
With other types of installation the ζ and Δp_t values should be multiplied by the correction factor F shown in table 10.1
- 10) All sound power levels conform to ISO 5135 (1997) and therefore are induct with dimensions B x H. The sound power values radiated from the duct are calculated from induct values less end reflection (see VDI 2081)
- 11) For type JZD-G the total pressure drop and sound power values in table 4 must be corrected.
 - Multiply total pressure drop by F_1
 - Sound power values are reduced by value K_1

α	10°	20°	30°	40°	50°	60°	70°
F_1	2.9	1.9	1.4	1.1	1.0	0.9	0.7
K_1	3	3	3	4	5	6	11

Sound power level and leakage volume flow with blades closed

5 Type JZ-A · JZ-B

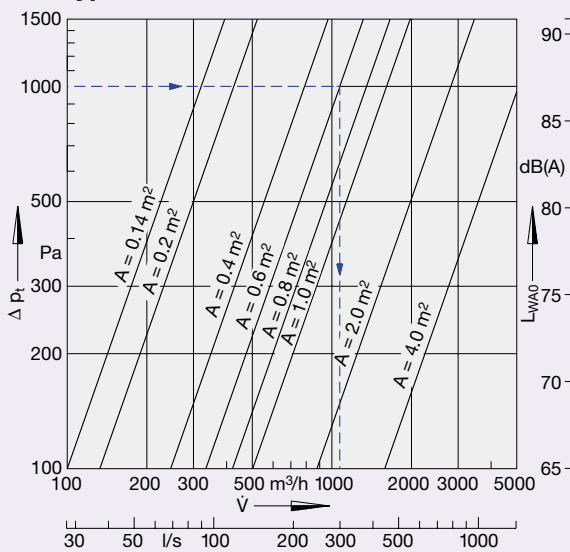

6 Type JZD-B

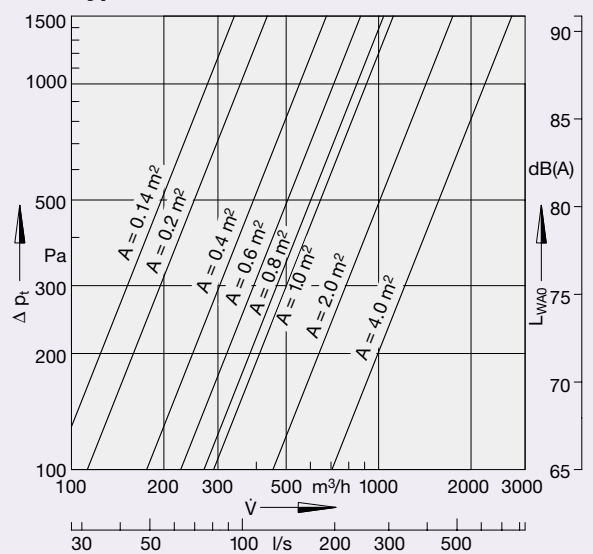

7 Type JZ-L

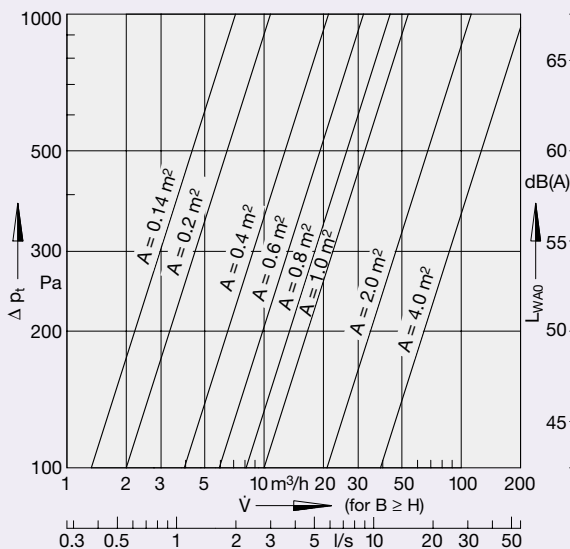

Technical Data

M_1 in Nm: Maximum required torque
 M_2 in Nm: Minimum torque
 a in cm: Torque coefficient (diagram 11)
 n : Number of blades (see page 9)

When air flows through the damper there occurs, due to aerodynamic forces – independent of airflow direction – a torque acting in the closing direction. When opening the damper, this must be overcome by the actuator. The blade angle α at which the greatest torque is required is dependant on the fan or system characteristics.

Type JZD-B

$$M_1 = \frac{a \cdot \Delta p_t \cdot A}{100}$$

$$M_2 = n \cdot 0.9^{12)}$$

Type JZD-G

$$M_1 = \frac{a \cdot \Delta p_t \cdot A}{100} + (n \cdot 1.3)^{12)}$$

$$M_2 = n \cdot 1.3^{12)}$$

Type JZ-L

$$M_1 = \frac{a \cdot \Delta p_t \cdot A}{100} + (n \cdot 1.2)^{12)}$$

$$M_2 = 8 \text{ to } 30 \text{ Nm (see table on page 13)}$$

Type JZ-A · JNE-A · JZ-B · JNE-B · JZ-G

$$M_1 = \frac{a \cdot \Delta p_t \cdot A}{100}$$

$$M_2 = n \cdot 0.6^{12)}$$

12) Friction moment

Sound power level and leakage volume for $\alpha =$ blades closed

8 Type JZ-G

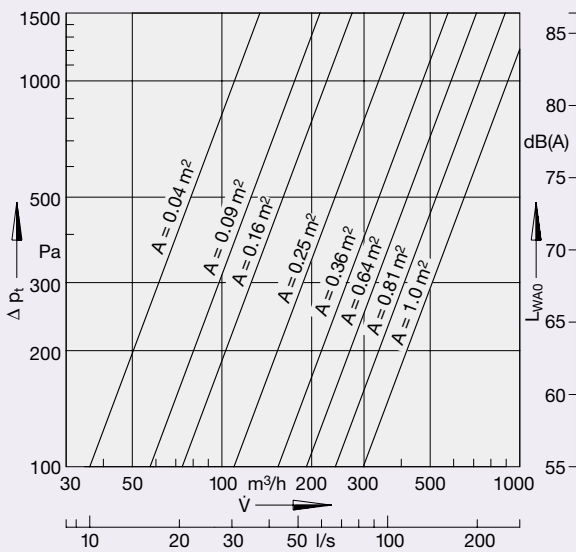

9 Type JZD-G

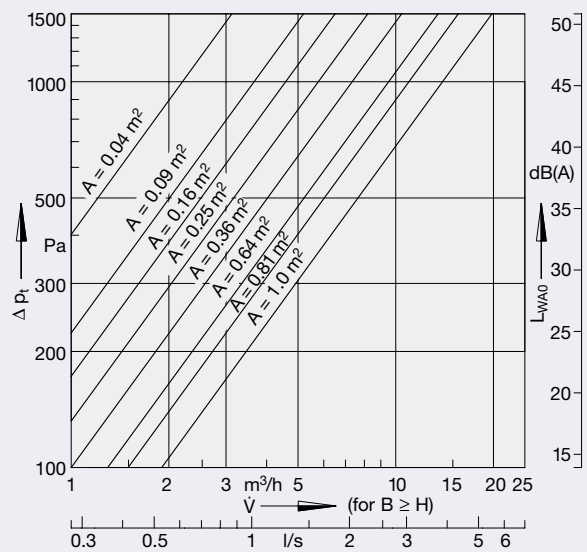

Calculation examples

Example 1: Type JZ-B, B x H = 600 x 1005 mm

Required: Δp_t , L_{WA} and L_{WNC} for installation type A, $\alpha = 40^\circ$ and $v = 4$ m/s

Result: $\Delta p_t = 108$ Pa
(from diagram 2)
 $L_{WA} = 66$ dB(A) - 2 = 64 dB(A)
(L_{WA} from diagram 2, K from table page 18)
 $L_{WNC} = 61 - 2 = 59$
(L_{WNC} from diagram 2, K from table page 18)

Example 2: Type JZ-B, B x H = 600 x 1005 mm

Required: L_{WA} , L_{WNC} and \dot{V} with blade closed and $\Delta p_t = 1000$ Pa

Result: $L_{WA} = 87$ dB(A) - 2 = 85 dB(A)
(L_{WA} from diagram 5, K from table page 18)
 $L_{WNC} = 85 - 2 = 83$
(L_{WNC} from diagram 5, K from table page 18)
 $\dot{V} \approx 300$ l/s ≈ 1080 m³/h
(from diagram 5)

Example 3: Type JZ-B, B x H = 1000 x 1005 mm

Required: Δp_{tB} and ζ_B for installation type B, $\alpha = 40^\circ$ and $v = 4$ m/s,
 $\Delta p_t = 108$ Pa (from diagram 2)
 $\zeta = 11$ (from diagram 10)
and $F = 1.5$ (from table 10.1)

Result: $\Delta p_{tB} = 108$ Pa x 1.5 = 162 Pa
 $\zeta_B = 11 \times 1.5 = 16.5$

Example 4: Type JZ-B, B x H = 1000 x 1005 mm

Required: M_t for installat. type A and $\Delta p_t = 130$ Pa, $\alpha = 20^\circ$, $a = 16$ cm;
 $\Delta p_t = 350$ Pa, $\alpha = 40^\circ$, $a = 3$ cm;
 $\Delta p_t = 700$ Pa, $\alpha = 60^\circ$, $a = 1.3$ cm;
 $\Delta p_t = 1000$ Pa, $\alpha \approx 90^\circ$, $a = 0.25$ cm

Result:

	α			
	20°	40°	60°	≈ 90°
Δp_t in Pa (estimated)	130	350	700	1000
a in cm (from diagram 11)	16	3	1.3	0.25
M_t in Nm (acc. to formula) on p. 16	21	10.6	9.2	2.5

Required torque = 21 Nm

10 Characteristics diagram

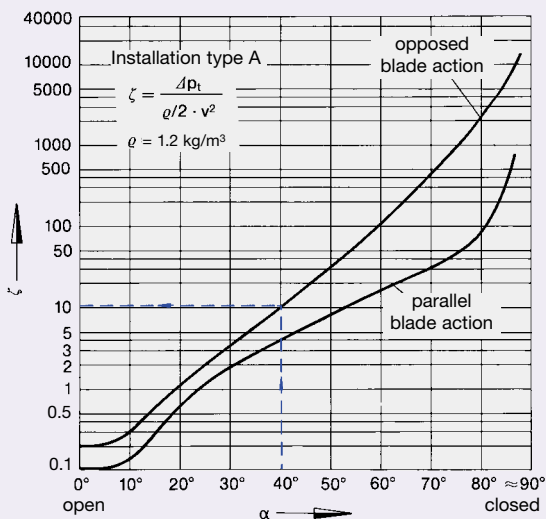

10.1 Type of installation

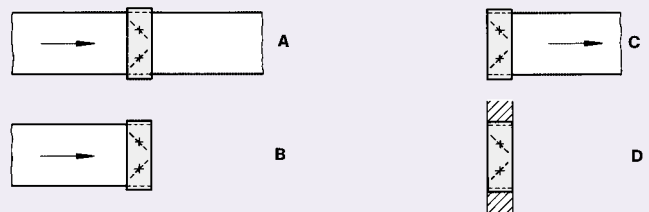

Type of inst.	Type of operation	Correction factors F where blade $\alpha =$							
		10°	20°	30°	40°	50°	60°	70°	80°
B	opposed	5.5	3.0	2.0	1.5	1.3	1.2	1.1	1.0
	parallel	10.0	3.5	2.0	1.5	1.3	1.2	1.1	1.0
C	opposed	3.5	2.3	1.7	1.4	1.3	1.2	1.1	1.0
	parallel	6.0	2.2	1.6	1.5	1.3	1.2	1.1	1.0
D	opposed	8.0	4.5	2.7	1.9	1.7	1.5	1.2	1.0
	parallel	15.0	5.0	2.4	1.9	1.7	1.5	1.2	1.0

11 Torque coefficient

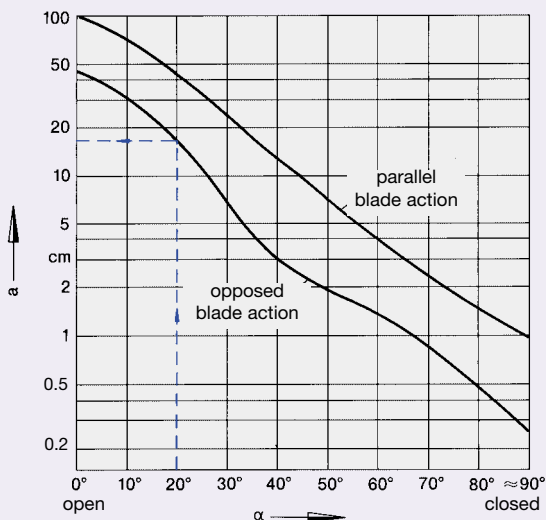

12 Max. allowed pressure when blades closed

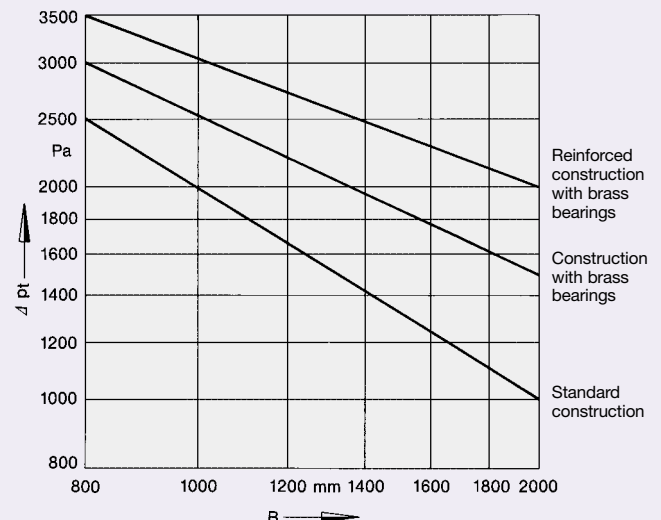

Technical Data

Sound power level spectra at various blade angles																																			
Type		JZ-A JNE-A								JZ-B JZD-B JNE-B								JZ-L								JZ-G									
Blade angle α	v in m/s	Sound power level (L_{wo} in dB/oct.)																																	
		f = 63								f = 125								f = 250								f = 500								f = 1000	
		63	125	250	500	1000	2000	4000	8000	63	125	250	500	1000	2000	4000	8000	63	125	250	500	1000	2000	4000	8000	63	125	250	500	1000	2000	4000	8000		
10	6	54	51	50	51	48	41	35	28	55	54	52	50	50	46	39	33	53	53	50	44	44	46	42	34	56	54	51	49	46	43	36	30		
	8	61	59	57	57	56	50	44	37	61	60	58	56	56	53	47	40	60	61	59	53	52	54	50	44	63	61	58	56	53	51	45	38		
	10	67	64	62	59	62	57	51	44	64	65	64	62	61	59	54	46	67	67	66	61	58	59	58	53	68	66	63	61	58	56	51	44		
	15	77	75	73	71	71	70	64	59	72	74	73	72	70	70	66	60	79	79	79	77	70	69	72	69	77	76	74	71	69	66	64	58		
	20	81	82	79	77	76	77	72	66	76	78	79	78	76	75	73	68	84	85	85	84	79	76	77	76	80	82	80	77	75	72	70	65		
20	6	58	56	54	55	51	45	39	32	59	57	56	55	54	51	44	38	58	58	55	49	49	51	47	40	61	59	56	54	51	49	43	36		
	8	65	62	60	60	60	54	48	41	64	64	63	61	61	59	55	48	65	66	63	58	57	58	56	50	68	66	64	61	59	56	52	45		
	10	71	68	66	65	66	61	55	48	68	69	68	66	65	64	60	53	72	72	71	66	63	63	64	58	73	72	70	67	65	62	58	52		
	15	78	78	75	74	73	71	66	59	74	77	77	75	73	73	71	67	81	82	82	80	75	73	74	72	80	80	78	76	73	71	68	64		
	20	84	85	82	80	79	80	75	69	79	82	83	82	80	79	78	74	89	90	90	89	84	81	81	82	85	86	85	83	80	78	75	71		
40	6	69	67	65	66	68	64	55	47	72	73	72	70	71	72	69	60	76	76	73	69	68	71	70	63	75	75	69	68	70	71	66	59		
	8	77	74	72	71	74	72	65	57	76	79	78	77	76	78	77	69	83	85	83	78	76	78	79	75	80	82	77	73	75	77	74	68		
	10	81	80	77	76	78	78	71	64	80	83	84	83	81	82	83	77	88	90	90	85	83	83	85	82	85	86	84	79	79	82	81	75		
	12	84	84	82	80	81	83	79	70	82	86	87	86	84	85	86	83	93	95	95	92	88	87	90	89	88	89	89	83	82	84	85	80		
60	2	57	54	56	57	54	45	36	28	67	68	67	64	66	67	62	53	69	68	65	61	60	64	62	55	69	69	67	69	69	66	59	52		
	4	73	71	69	70	72	68	59	51	79	81	82	81	78	80	81	76	85	88	87	84	79	79	82	80	79	83	83	81	83	83	80	73		
	6	84	82	79	78	80	80	73	65	85	88	91	89	88	87	90	88	95	98	99	96	92	90	92	92	85	89	91	90	90	91	89	84		
	8	88	88	86	84	85	87	83	74	90	93	95	96	95	92	94	95	102	104	107	106	102	98	98	101	88	92	96	96	94	96	96	93		
80	0.5	41	40	42	41	34	26	18	15	55	59	62	60	63	67	66	64	54	55	57	59	64	64	60	52	62	66	66	64	66	66	62	56		
	0.8	53	51	50	53	51	43	35	27	62	65	69	70	69	73	76	74	64	67	68	71	72	77	76	73	69	72	76	76	74	76	76	72		
	1.0	59	56	55	57	56	49	41	33	66	69	73	76	74	77	81	80	69	73	73	75	77	83	82	79	73	76	80	80	78	80	80	76		
	1.2	63	61	59	60	62	57	49	41	68	72	75	79	78	78	84	84	74	76	76	80	83	86	87	87	74	78	83	84	82	84	84	81		

Sound power level spectra with blades closed																																	
Type		JZ-A JNE-A								JZ-B JZD-B JNE-B								JZ-L								JZ-G							
Δp_t in Pa	f	Sound power level (L_{wo} in dB/oct.)																															
		f = 63								f = 125								f = 250								f = 500							
		63	125	250	500	1000	2000	4000	8000	63	125	250	500	1000	2000	4000	8000	63	125	250	500	1000	2000	4000	8000	63	125	250	500	1000	2000	4000	8000
100		54	47	54	62	63	60	50	37	54	47	54	62	63	60	50	37	39	34	31	36	36	34	36	28	47	46	46	52	51	50	46	36
200		56	51	56	65	67	66	60	48	56	51	56	65	67	66	60	48	44	39	37	41	42	42	43	37	51	50	51	57	57	57	55	46
500		60	56	58	68	71	74	73	62	60	56	58	68	71	74	73	62	52	47	44	48	51	55	54	50	57	55	56	64	66	68	67	59
1000		63	60	60	70	75	80	82	74	63	60	60	70	75	80	82	74	57	52	50	53	57	60	62	60	62	59	61	68	73	76	75	69
1500		65	61	56	67	73	82	88	79	65	61	56	67	73	82	88	79	60	55	53	56	60	63	66	66	64	60	63	70	77	80	79	74
2000		66	63	61	72	79	85	91	84	66	63	61	72	79	85	91	84	64	58	56	58	64	66	70	70	66	62	65	73	80	84	84	78

Sound power level correction factors														
A in m ²	0.10	0.12	0.25	0.30	0.40	0.50	0.60	0.75	1.00	1.25	1.60	2.00	3.00	4.00
K	-10	-9	-6	-5	-4	-3	-2	-1	0	+1	+2	+3	+5	+6

All technical data relates to standard dimensions.

Order code

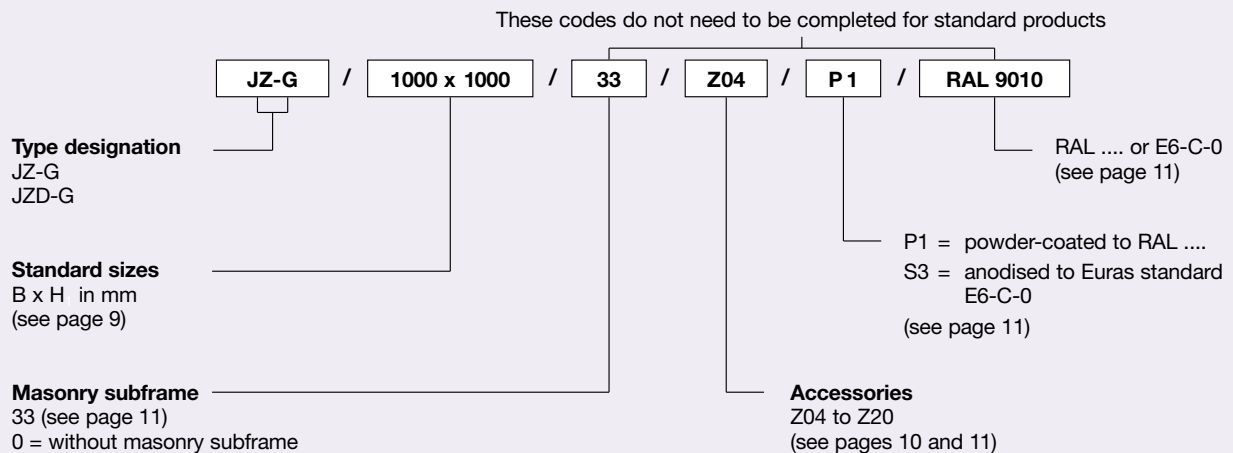
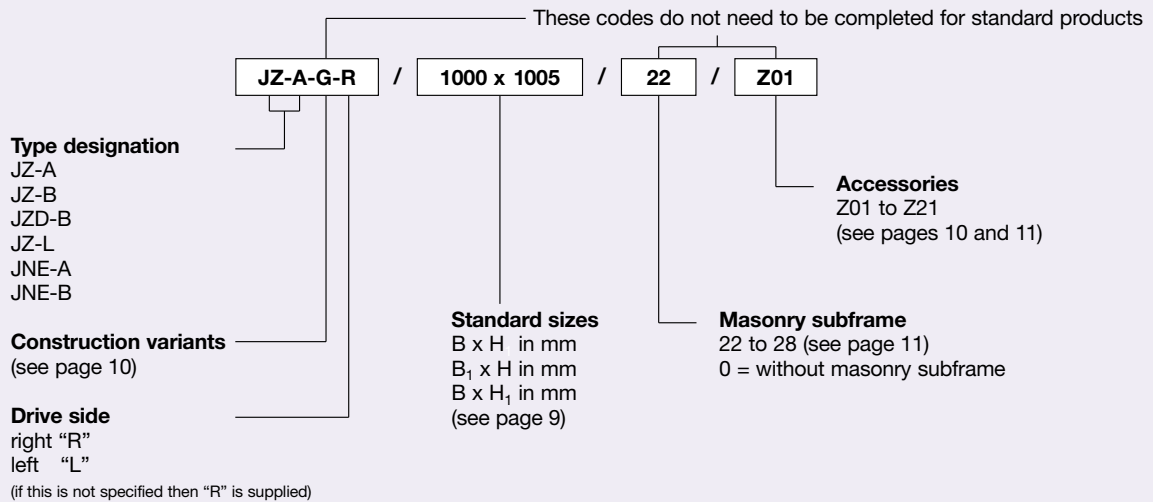

Specification text

Multileaf dampers designed for volume flow and pressure control or to isolate sections of ducting in ventilation systems, basically consisting of a channel shaped casing, aerofoil blades, connected by external linkage or internal gears (type JZ-G · JZD-G).

Material:
 details of this on pages 3 to 6

Masonry subframe, accessories:
 see pages 10 and 11 for details

Make: TROX

Type and construction variants:
 see page 10 for details

Order example

Make: TROX
Type: JZ-A-G-R / 1000 x 1005 / 22 / Z01
Number: 6

