

Siv-inn T/V

Diffuser for high air flow rates

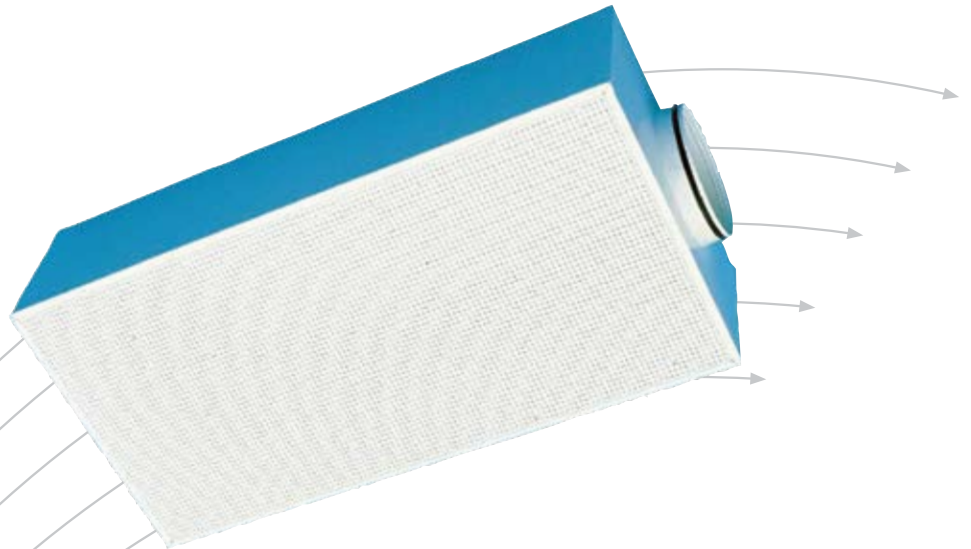

- Suitable for T-profile ceiling system
- Removable front
- Large capacity

TROX[®] TECHNIK

 **Auranor**

TROX Auranor Norge AS

PO Box 100
NO-2712 Brandbu

Telephone: +47 61 31 35 00
Fax: +47 61 31 35 10
e-mail firma@auranor.no
www.auranor.no

Siv-inn T/V



APPLICATION

Siv-inn T/V is a supply diffuser for areas requiring high air flow rates such as commercial kitchens or laboratories. Suitable for open as well as embedded installation (see fig. 2).

DESIGN

The product is available in 6 different sizes, with circular end-spigot as standard. External dimensions are designed to fit T-profile ceiling systems with module 600. Alternative connection solutions and positioning are available on request. Siv-inn T/V can also be supplied with perforated sides. The front panel is reinforced and can be removed by unfastening the screws.

MATERIALS AND SURFACE COATING

Siv-inn T/V comes in a galvanised steel-plate design. Sides and front are in a white RAL 9010 finish.

QUICK SELECTION

Siv-inn T/V Type	[m ³ /h]		
	25 dB(A)	30 dB(A)	35 dB(A)
0312	230	300	430
0612	340	470	580
0618	540	680	860
1212	700	900	1200
1218	1000	1200	1600
1224	1200	1600	2000

Table 1: The table shows air flow rates at given sound power levels.

ORDER CODE, Siv-inn T/V

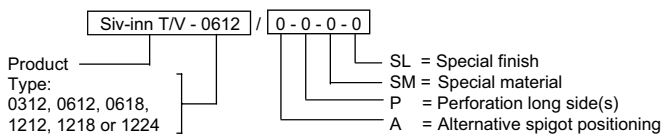

Example:
 Siv-inn T/V-0612 / 0-0-0-0
 Explanation:
 Siv-inn T/V, type: 0612 with spigot Ø250.

WEIGHT AND DIMENSIONS, Siv-inn T/V

Type	A	B	C	D	[kg]
0312	1190	290	270	199	10,0
0612	1190	590	320	249	18,5
0618	1790	590	320	249	27,0
1212	1190	1190	380	314	37,0
1218	1790	1190	380	314	55,5
1224	2390	1190	480	399	74,0

Table 2

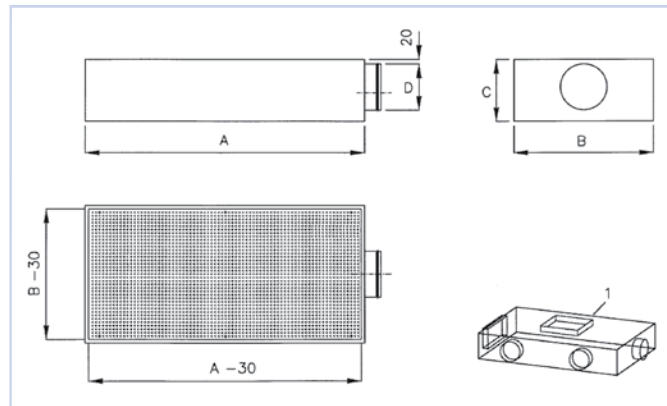

Fig. 1

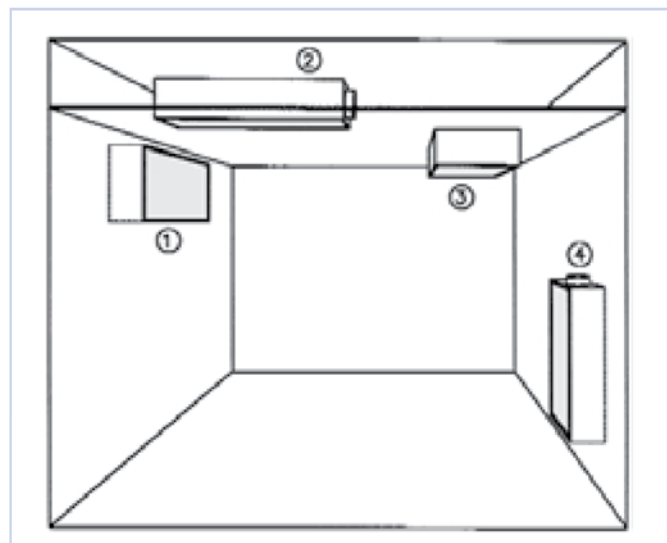

Fig. 2

Siv-inn T/V

ACOUSTIC DATA

The diagram provides a summary of the A-weighted sound power level from diffuser, L_{WA} . Correction factors in table 4 are used to calculate emitted sound power level at the respective frequencies, $L_W = L_{WA} + KO$. A room with absorption equivalent to 10m² Sabine will have a sound pressure level which is 4 dB below the sound power level emitted.

Example:

An auditorium requires an air supply of 300 l/s, and for this purpose a Siv-inn T/V 1212 is used. Room attenuation is 4 dB. From the diagram, we find that $L_{WA} = 34$ dB(A) and the total pressure loss is 25 Pa.

We aim to find:

- a) Emitted sound power level from one diffuser at 250 Hz.
- b) A-weighted sound pressure level in the room.

- a) According to table 4, the correction factor for 250 Hz is -1 dB. L_W at 250 Hz is thus: $L_{WA} + KO = 34 + (-1) = 33$ dB
- b) A room attenuation equivalent to 4 dB provides a sound pressure level in the room of: $34 - 4 = 30$ dB(A)

CALCULATION DIAGRAM

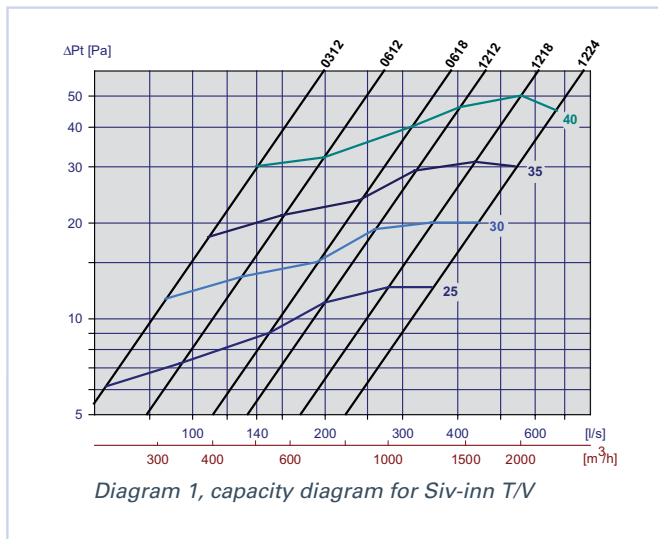

Static sound attenuation incl. end reflection, Siv-inn T/V

Siv-inn T/V Type	Attenuation [dB]							
	63	125	250	500	1k	2k	4k	8k
0312	16	9	4	3	12	15	14	13
0612	14	9	3	3	11	15	13	13
0618	14	11	3	2	5	6	10	9
1212	12	10	3	2	5	6	10	9
1218	12	10	2	2	5	6	9	8
1224	11	9	3	2	5	5	9	8

Table 3

Correction factor [KO], Siv-Inn T/V

Siv-inn T/V Type	KO [dB]							
	63	125	250	500	1k	2k	4k	8k
0312	3	5	4	-3	-5	-16	-17	-18
0612	4	5	4	-4	-7	-17	-17	-19
0618	0	1	0	-2	-6	-15	-18	-18
1212	1	1	-1	-3	-5	-15	-17	-17
1218	4	5	3	-3	-5	-11	-17	-18
1224	3	5	2	-2	-5	-11	-16	-17

Table 4

Siv-inn T/V

FLOW PATTERN

Diagram A shows the air flow pattern and near-field measured from the unit at a 0.2 m/s end-speed. Diagrams C and D provide the velocity profile, the 0.2 m/s isovel, for wall mounting.

All diagrams show the flow pattern for three different air flow rates and at a lower temperature of 3 and 5 °C respectively. The data is based on $t_{in} = 18^{\circ}\text{C}$ and $t_{room} = 21/23^{\circ}\text{C}$.

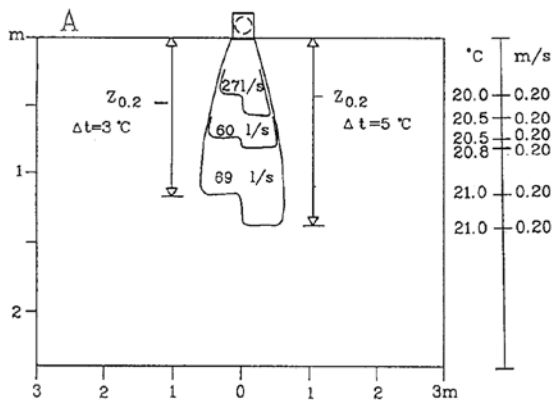

EXAMPLE:

Type 0312 mounted in ceiling will, at 60 l/s and $\Delta t = 5^{\circ}\text{C}$, provide a near-field of 0.8 m ($Z_{0.2}$) from ceiling. The temperature gradient in the supply zone is shown on the temperature scale to the right.

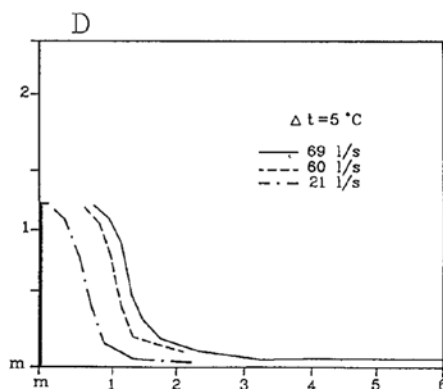
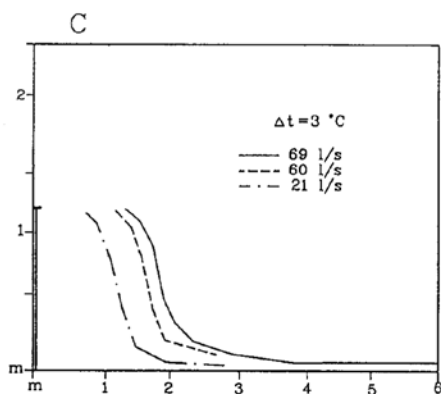

Diagram 2, Siv-inn T/V, 0312

Siv-inn T/V

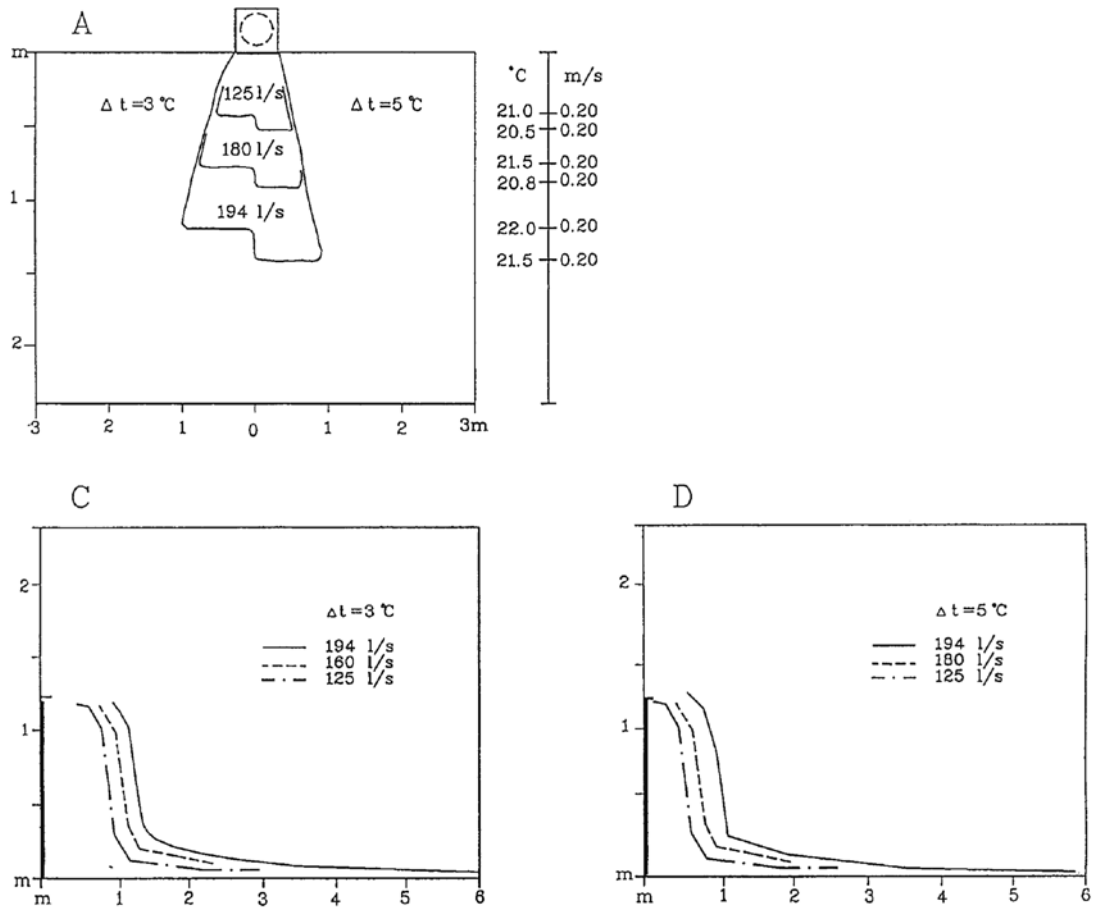

Diagram 3, Siv-inn T/V, 0612

Siv-inn T/V

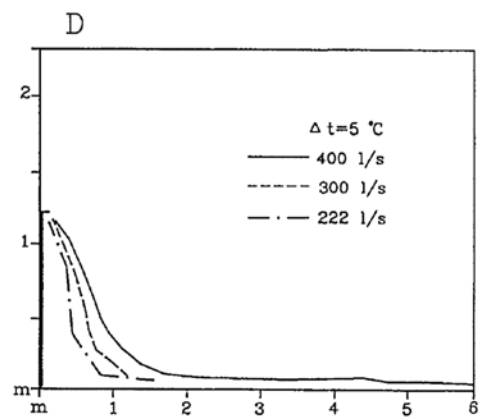
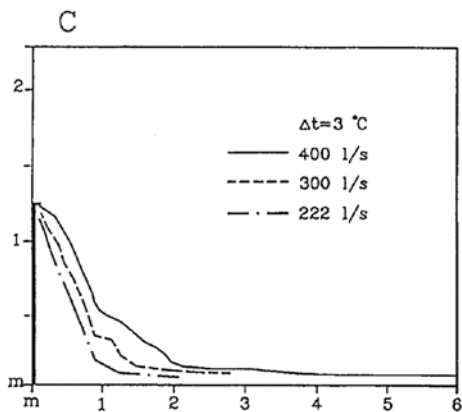
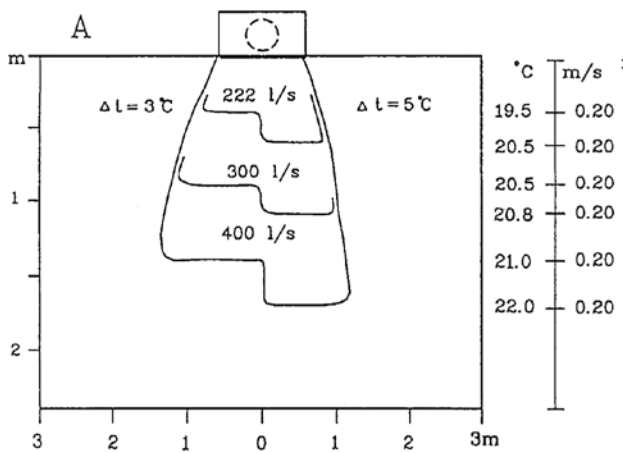
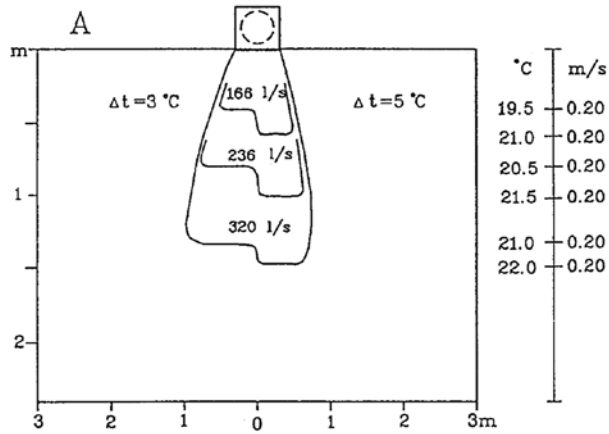

Diagram 5, Siv-inn T/V, 1212

Siv-inn T/V

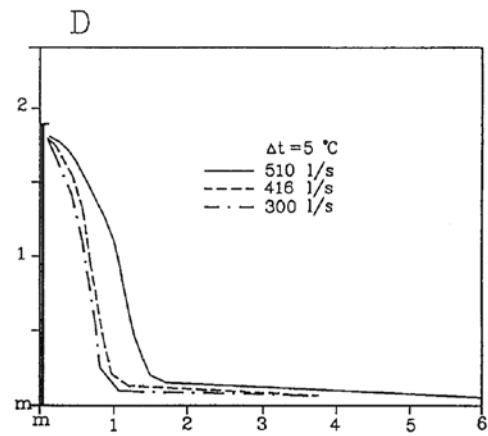
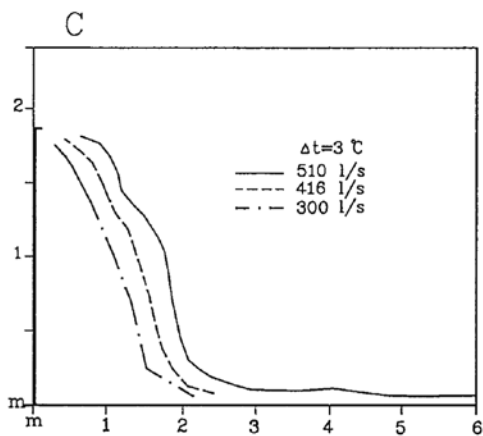
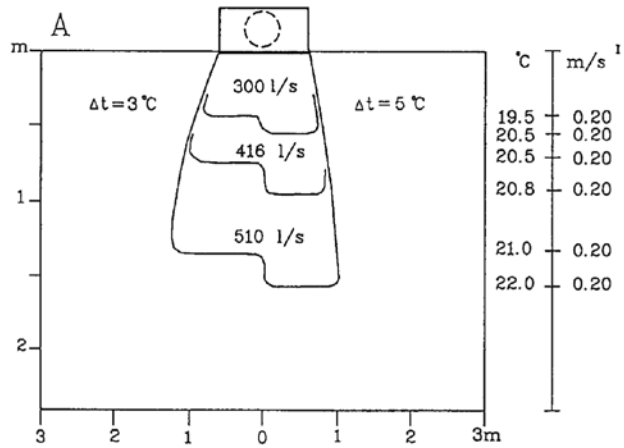

Diagram 6, Siv-inn T/V, 1218

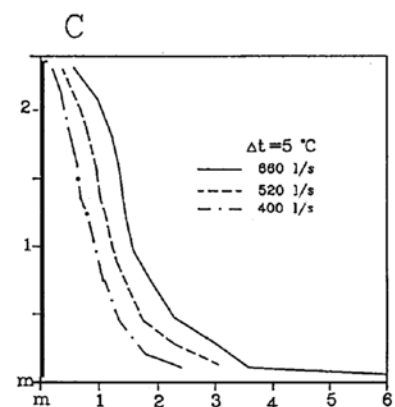
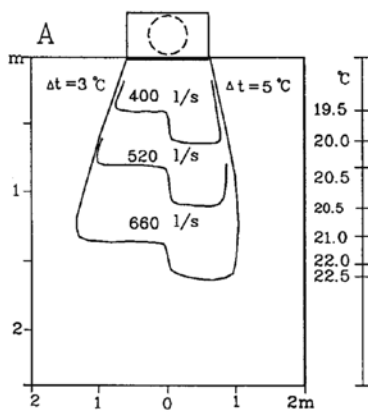

Diagram 7, Siv-inn T/V, 1224

Siv-inn T/V

INSTALLATION

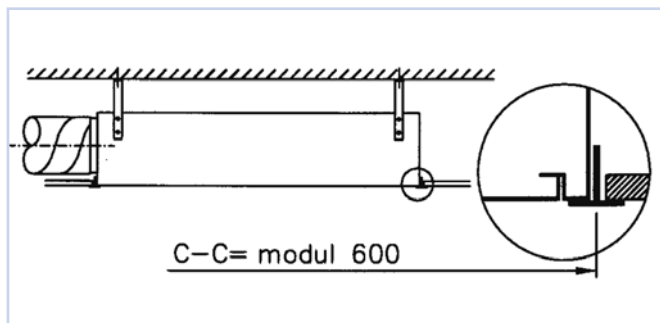

Fig 3: Installation in ceiling, designed to fit T-profile ceiling system.

MAINTENANCE

The diffuser can be cleaned by using a damp cloth.
When cleaning of ductwork, the diffuser front must be removed.

ENVIRONMENT

Enquiries regarding product declaration can be directed to our sales team, or information can be found at our website:
www.auranor.no

Siv-inn T/V is developed and manufactured by:

TROX[®] TECHNIK

The company reserves the right to make amendments
without prior notice.

Head Office:
TROX Auranor Norge AS, PO Box 100, NO-2712 Brandbu
Telephone: +47 61 31 35 00 Fax: +47 61 31 35 10
www.auranor.no