

Siv-inn Inlaid

Diffuser for displacement ventilation
Embedded installation

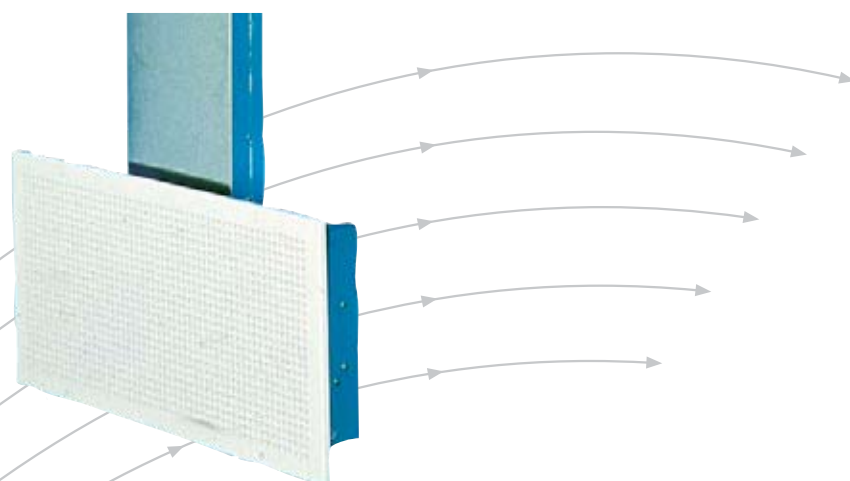

- Large capacity
- Adjustable wall duct
- Easy-clean design

TROX[®] TECHNIK

 **Auranor**

TROX Auranor Norge AS

PO Box 100
NO-2712 Brandbu

Telephone: +47 61 31 35 00
Fax: +47 61 31 35 10
e-mail firma@auranor.no
www.auranor.no

Siv-inn Inlaid



APPLICATION

The 300x600, 600x300, 400x400, 600x600 and 600x900 product range comprises air supply units for displacement ventilation, and is designed for embedded installation in wall.

DESIGN

Siv-inn Inlaid features a duct, box and front grille. Duct height can be adjusted as stated in table 2. The front grill is available in 5 dimension options, and is easily assembled with the screws supplied.

MATERIALS AND SURFACE COATING

Siv-inn Inlaid is made of solid steel plate. The front panel is fitted with a gasket and comes in a RAL 9010 finish as standard, while the box and duct are in a galvanised steel-plate finish. Reinforced front panel is available on request.

QUICK SELECTION

Siv-inn Inlaid Type	[m³/h]		
	25 dB(A)	30 dB(A)	35 dB(A)
1	140	160	180
2	200	250	300
3	290	400	470

Table 1: The table shows air flow rates at given sound power levels.

Type 1 = Dim. 300x600, 400x400 og 600x300

Type 2 = Dim. 600x600

Type 3 = Dim. 600x900

ORDER CODE, Siv-inn Inlaid

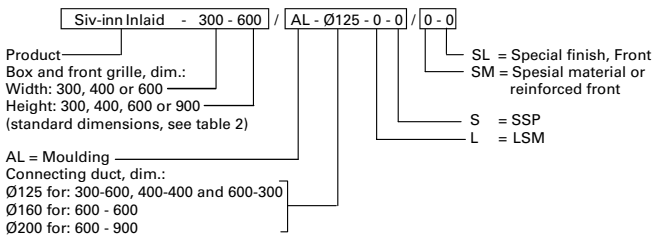

Example:
Siv-Inn Inlaid-300-600 / AL-Ø125-0-0 / 0-0

Explanation:
Siv-inn Inlaid, box and front dimensions: 300 x 600. Supplied with moulding and connecting duct Ø125.

DIMENSIONS AND WEIGHT, Siv-inn Inlaid

Dim.	B	H	C	D	BK	HK	E	F	L	weight* [kg]
300-600	300	600	72	125	243	543	210	49	1355-2620	11
600-300	600	300	72	125	543	243	210	49	1625-2620	11
400-400	400	400	72	125	343	343	210	49	1625-2620	12
600-600	600	600	72	160	543	543	500	49	1390-2350	21
600-900	600	900	92	200	543	843	500	64	1420-2350	25

Table 2: Siv-inn Inlaid (*weight with duct)

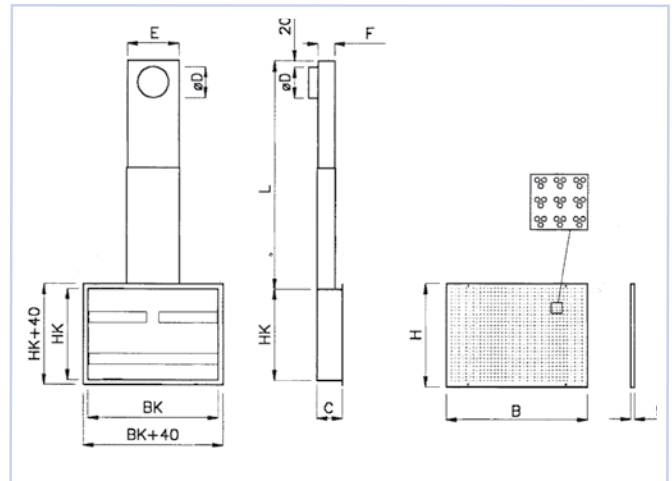

Fig. 1: Siv-inn Inlaid

Siv-inn Inlaid

ACOUSTIC DATA

ACOUSTIC DATA

The diagram provides a summary of the A-weighted sound power level from diffuser, L_{WA} . Correction factors in table 4 are used to calculate emitted sound power level at the respective frequencies, $L_W = L_{WA} + KO$. A room with absorption equivalent to 10m² Sabine will have a sound pressure level which is 4 dB below the sound power level emitted.

Example:

A small meeting room requires an air supply of 80 l/s, and for this purpose a Siv-inn Inlaid, type 600x600, is used. Room attenuation is 6 dB. From the diagram, we find that $L_{WA} = 33$ dB(A) and the total pressure loss is 40 Pa.

We aim to find:

- a) Emitted sound power level from the diffuser at 250 Hz.
 - b) A-weighted sound pressure level in the room.
- a) According to table 4, the correction factor for 250 Hz is -2 dB. L_W at 250 Hz is thus: $L_{WA} + KO = 33 + (-2) = 31$ dB
 - b) A room attenuation equivalent to 6 dB provides a sound pressure level in the room of: $33 - 6 = 27$ dB(A)

CALCULATION DIAGRAM

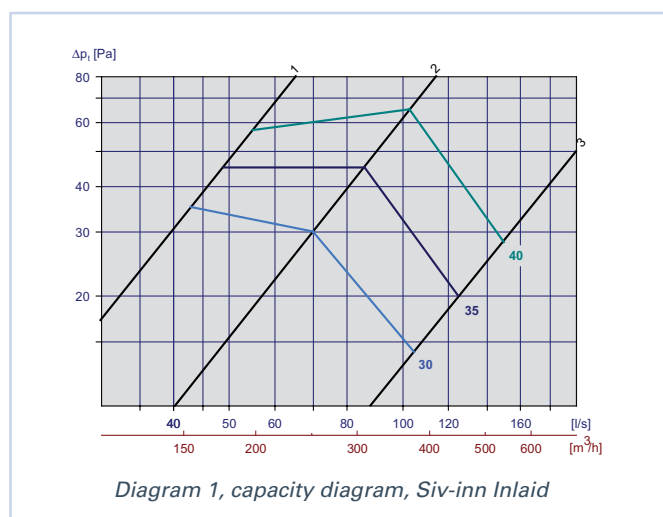

- 1 = type 300x600, 400x400 og 600x300
- 2 = type 600x600
- 3 = type 600x900

Static sound attenuation incl. end reflection, Siv-inn Inlaid

Siv-inn Inlaid Dim.	Attenuation [dB]							
	63	125	250	500	1k	2k	4k	8k
300-600	20	16	10	4	13	7	7	9
600-300	20	16	10	4	13	7	7	9
400-400	20	14	7	6	6	4	6	9
600-600	18	15	6	6	5	4	5	9
600-900	16	17	9	5	14	7	6	8
900-600	16	17	9	5	14	7	6	8

Table 3: Siv-inn Inlaid

Correction factor [KO], Siv-Inn Inlaid

Siv-inn Inlaid Dim.	KO[dB]							
	63	125	250	500	1k	2k	4k	8k
300-600	0	0	-2	-2	-5	-11	-17	-15
600-300	0	0	-2	-2	-5	-11	-17	-15
400-400	-3	-4	-1	-1	-5	-10	-15	-15
600-600	-4	-3	-2	-2	-5	-9	-15	-15
600-900	-1	0	-2	-2	-5	-11	-16	-15
900-600	-1	0	-2	-2	-5	-11	-16	-15

Table 4, Siv-inn Inlaid

Siv-inn Inlaid

NÆRSONE

Data in table 6 is measured at a room temperature (trom) of 23 °C and air supply temperatures (tinn) of 20 °C and 17 °C with Δt equivalent to 3 °C and 6 °C respectively.

Inlet vanes for sideway adjustment of flow pattern are available on request.

$\Delta t = T_{in} - T_{room}$, i.e. the difference between supply-air temperature (t_{in}) and room temperature (t_{room}) measured 1.1m above floor level.

$L_{0.2}$ = distance (in m) from wall to the 0.2 m/s isovel measured 0.1 m above floor level. If measured 0.05 m above floor level, $L_{0.2}$ increases by approx. 0.5 m.

$B_{0.2}$ = distance in m along wall from the centre of the unit to the 0.2 m/s isovel measured 0.1 m above floor level. If measured 0.05 m above floor level, $B_{0.2}$ increases by approx. 0.5 m.

$^{\circ}C_{0.2}$ = temperature in °C measured in the 0.2 m/s isovel, 0.1m above floor level.

Siv-inn Inlaid		$\Delta t = 3^{\circ}C$			$\Delta t = 6^{\circ}C$		
Dim	[m ³ /h]	$L_{0.2}$	$B_{0.2}$	$^{\circ}C_{0.2}$	$L_{0.2}$	$B_{0.2}$	$^{\circ}C_{0.2}$
300-600	100	0,50	0,60	21,0	0,60	0,70	18,50
	125	0,50	0,70	21,0	0,60	0,80	18,50
400-400	100	0,50	0,60	21,0	0,70	0,70	18,00
	125	0,50	0,60	21,0	0,80	0,90	18,50
600-300	100	0,60	1,00	21,0	0,90	1,30	19,00
	125	0,80	1,30	21,0	1,00	1,60	19,50
600-600	200	1,50	1,70	22,0	2,20	2,30	20,00
	250	1,80	1,90	22,0	2,70	2,80	21,00
600-900	400	2,00	1,70	21,0	2,40	2,50	20,00
	450	2,70	2,00	21,0	3,00	3,20	21,00

Table 5

FLOW PATTERN

In order to direct the air supply to one or both sides, an easy-to-install shutter unit has been developed. This unit can also be fitted to existing systems. The shutter units can be fitted and removed without tools, and provide excellent commissioning options and flexibility in terms of furnishings.

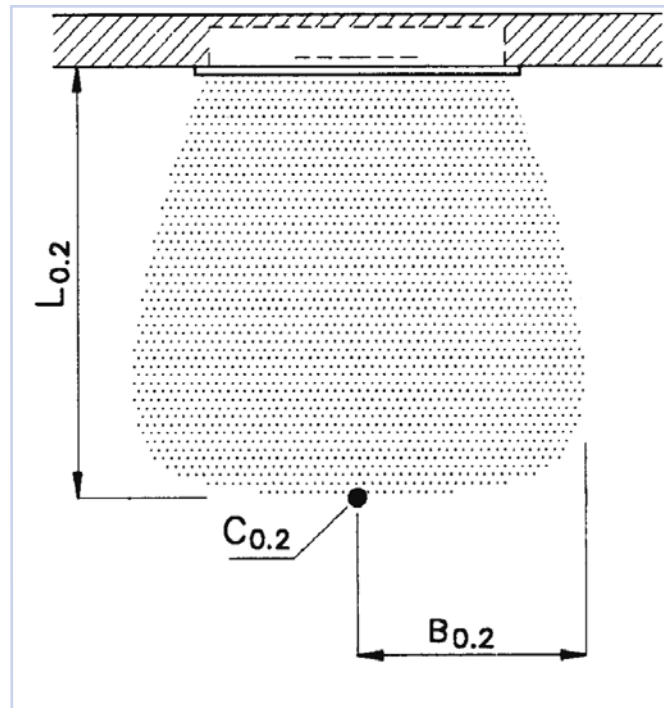

Fig. 2: Siv-inn Inlaid

Siv-inn Inlaid

INSTALLATION

Groove dimensions for box are BK x HK + approx. 5 mm. The height of the connecting duct is adjustable (see table 2, dim. L). Duct height is adjusted and sealed prior to installation in wall. NBI! If the unit is attached directly to the studding, the moulding should be fitted after the wainscot (see fig. 3). The front panel is fitted by using the screws supplied. Please also see the instructions.

- Pos. no. in fig. 3:
1. Connecting duct
 2. Box
 3. Front
 4. Moulding
 5. LSM
 6. SSP

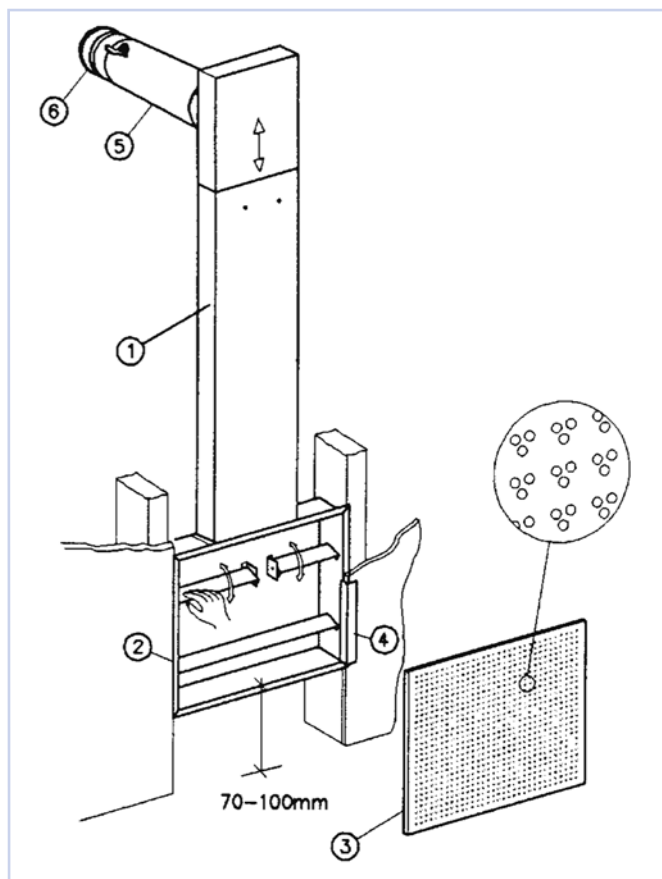

Fig. 3

Siv-inn Inlaid is developed and manufactured by:

COMMISSIONING

The air flow rate is established by measuring the pressure loss at the front centre by using a measuring head. Correction factors for calculation of air flow rates are provided on the label inside the diffuser, or can be found in our commissioning guide at our website: www.auranor.no.

MAINTENANCE

The front panel is removable and comes in an enamel finish. Cleaning the unit is thus a straightforward process.

ENVIRONMENT

Enquiries regarding product declaration can be directed to our sales team, or information can be found at our website: www.auranor.no

The company reserves the right to make amendments without prior notice.