

USI

Extract air terminal device for open installation

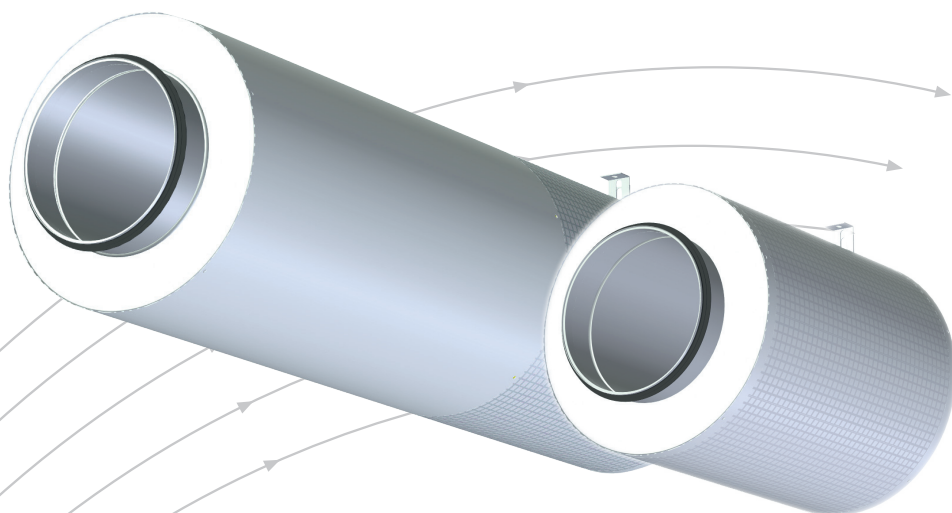

- Large capacity
- Available with integrated sound attenuator
- Cleanable
- Easy installation – ideal for renovation work
- Suitable for schools and large premises
- Dimensions from Ø200 – Ø500

TROX[®] TECHNIK

 **Auranor**

TROX Auranor Norge AS

PO Box 100
NO-2760 Brandbu

Telefon +47 61 31 35 00
Telefaks+47 61 31 35 10
e-mail: firmapost@auranor.no
www.trox.no

USI

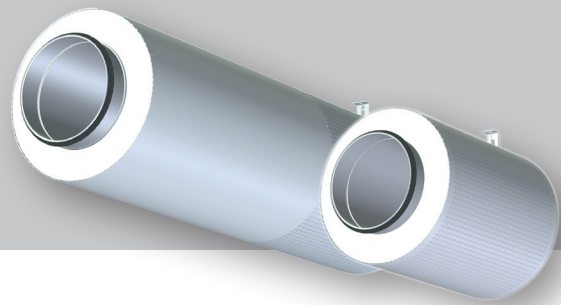

APPLICATION

The USI extract air terminal is intended for open installation. It is suitable for high air flow rates, and can thus be used as a central extraction unit in large rooms – ideal in combination with VAV.

DESIGN

The valve is available with and without integrated sound attenuator.

MATERIALS AND SURFACE COATING

The device is made of galvanised steel, and comes in RAL 9010. Other colours are available on request.

QUICK SELECTION

USI Dim	[m ³ /h]		
	25dB(A)	30dB(A)	35dB(A)
200	396	490	605
250	662	796	954
315	896	1087	1318
400	1786	2124	2525
500	2228	2804	3528

Table 1: The table shows air flow rates at given sound power levels.

ORDER CODE, USI

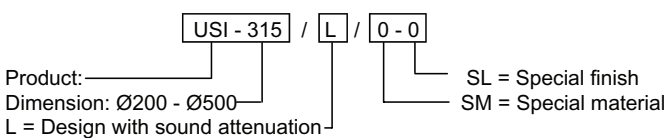

Example:
USI-315 / L / 0-0
Explanation:
USI dim. Ø315, with sound attenuation

DIMENSIONS AND WEIGHT, USI

Dim.	D	A	Weight[kg] ¹	Weight[kg] ²
200	199	320	4,0	11,7
250	249	365	4,4	13,0
315	314	435	5,4	15,7
400	398	528	6,8	19,5
500	498	620	8,5	25,5

Table 2: ¹ without sound attenuator, ² with sound attenuator

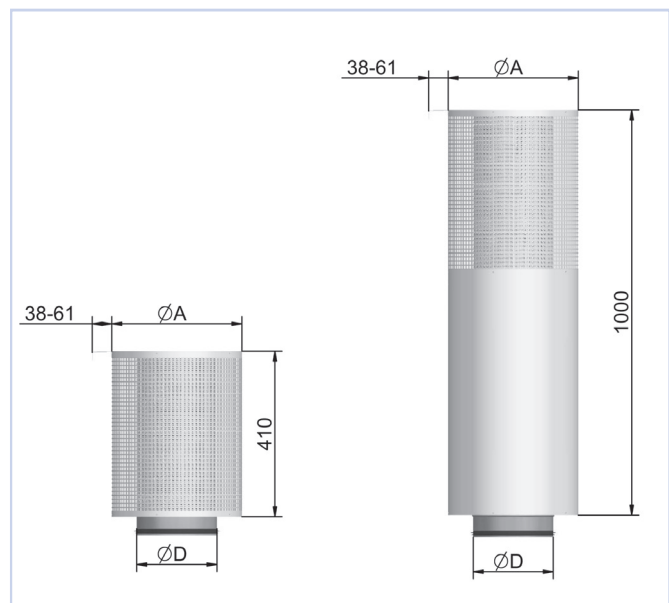

Fig. 1

USI

ACOUSTIC DATA

The diagram provides a summary of the A-weighted sound power level from diffuser, L_{WA} . Correction factors in table 5 are used to calculate emitted sound power level at the respective frequencies, $L_W = L_{WA} + KO$.

A room with absorption equivalent to 10m² Sabine will have a sound pressure level which is 4 dB below the sound power level emitted.

Table 3 and 4 show the static sound attenuation including end reflection.

Example:

A room requires an indoor air extraction level of 180 l/s, and for this purpose a USI 250 with attenuator is used. Room attenuation is estimated to 6 dB.

We aim to find:

- a) Emitted sound power level from one valve at 250 Hz.
- b) A-weighted sound pressure level in the room from one valve.

Solution:

According to diagram 1, $L_{WA} = 25$ dB(A) at 8 Pa total pressure loss.

a) Table 5 shows a correction factor for 250 Hz of 0 dB.

L_W at 250 Hz is thus: $L_{WA} + KO = 25 + (0) = 25$ dB

b) A room attenuation equivalent to 6 dB provides a sound pressure level in the room of: $25 - 6 = 19$ dB(A)

CALCULATION DIAGRAMS

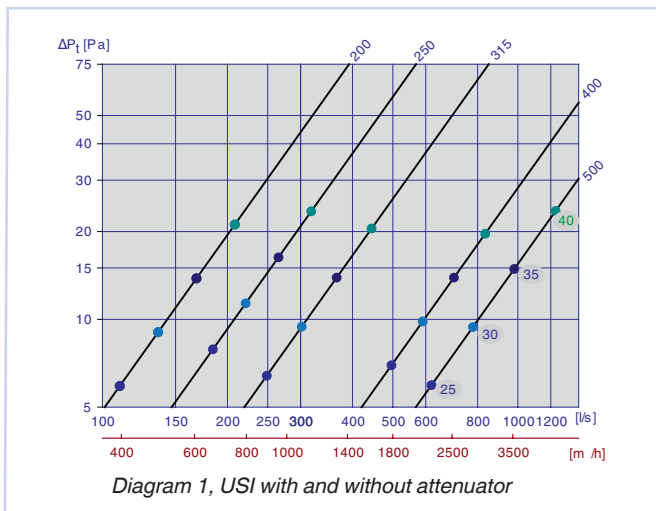

Static sound attenuation incl. end reflection for USI

USI	Attenuation [dB]							
Dim.	63	125	250	500	1k	2k	4k	8k
200	19	14	18	22	32	22	15	13
250	17	13	15	21	27	16	14	11
315	15	10	12	16	21	12	12	10
400	11	8	8	14	13	9	7	7
500	9	7	8	12	16	7	6	4

Table 3: USI with sound attenuator

Static sound attenuation incl. end reflection for USI

USI	Attenuation [dB]							
Dim.	63	125	250	500	1k	2k	4k	8k
200	19	13	7	3	1	1	1	1
250	17	11	6	2	1	1	1	1
315	15	9	4	2	2	1	1	1
400	13	7	3	2	1	1	1	1
500	9	2	1	1	1	1	1	1

Table 4: USI without sound attenuator

Correction factor [KO], USI

USI	Center frequency Hz							
Dim.	63	125	250	500	1k	2k	4k	8k
200	-3	-4	-8	-8	-6	-5	-15	-25
250	2	3	0	-5	-8	-7	-15	-25
315	4	5	1	-4	-7	-6	-15	-25
400	5	-4	-3	-4	-5	-7	-12	-22
500	7	2	-1	-2	-8	-14	-11	-7

Table 5

INSTALLATION

Installation principle is shown in fig. 2.

COMMISSIONING

A separate measurement and adjustment unit for commissioning is recommended.

MAINTENANCE

The valve can be cleaned by using a damp cloth.

ENVIRONMENT

Enquiries regarding product declaration can be directed to our sales team, or information can be found at our website: www.trox.no

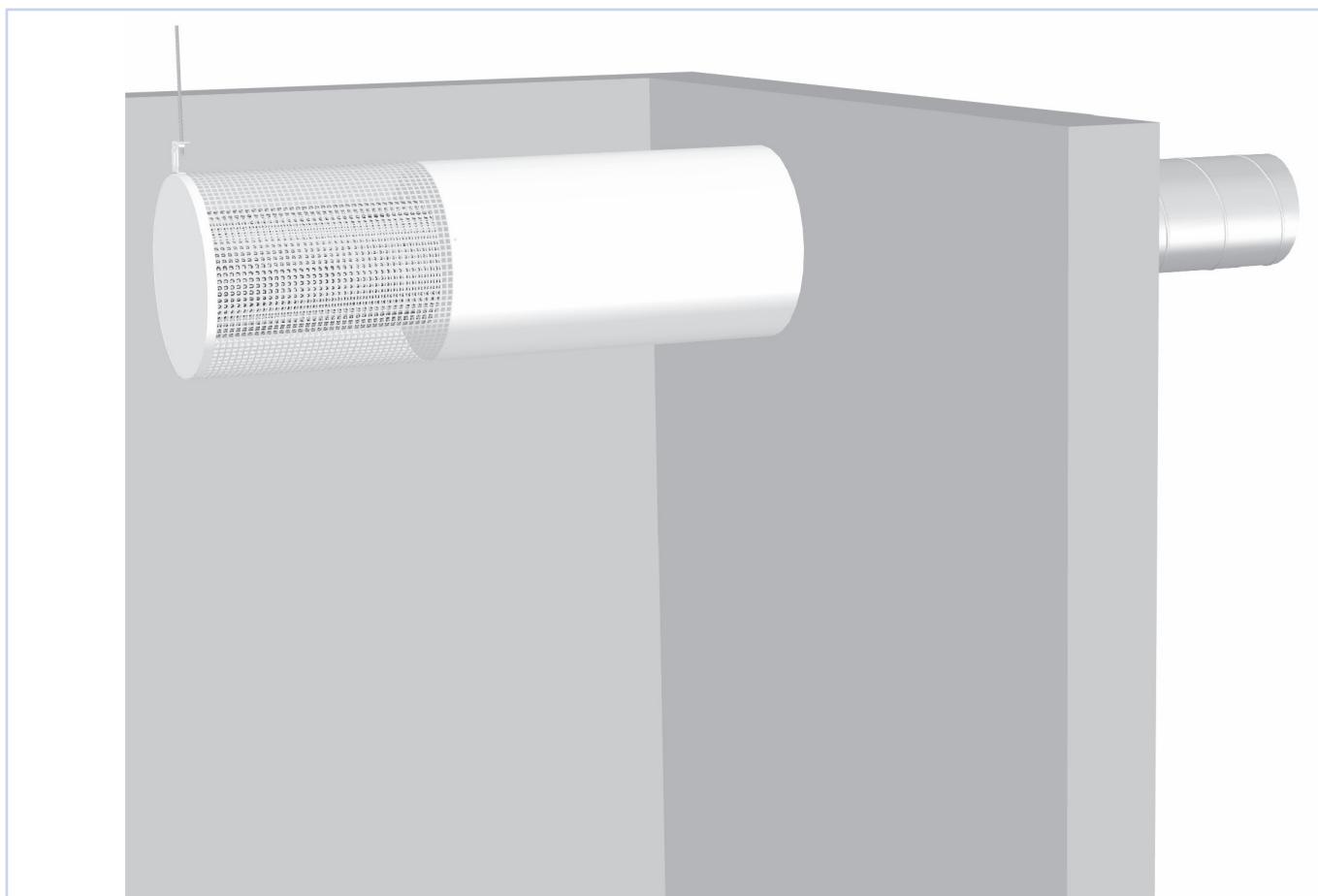

Fig. 2: Installation

USI is developed and manufactured by:

The company reserves the right to make amendments without prior notice.