

TIH and TIR

Industrial diffusers for open/freely
suspended installation

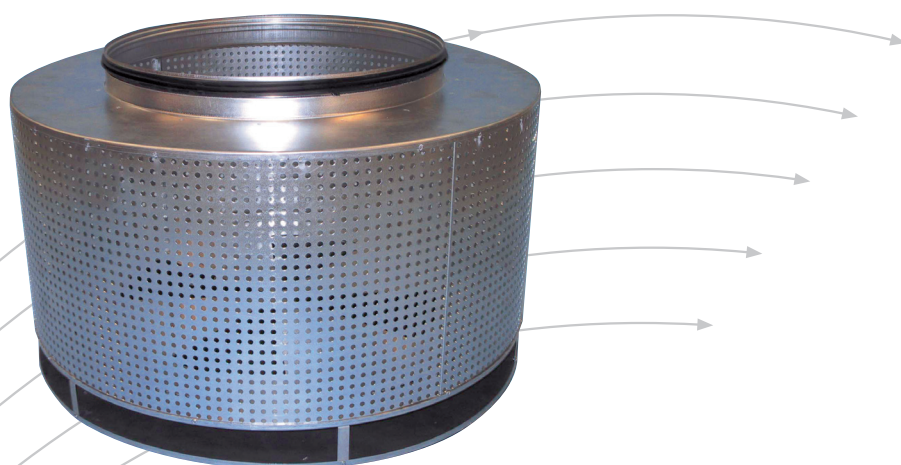

- TIR – freely suspended with adjustable throw length
- TIH – for wall or ductwork installation
- Suitable for both cooling and heating purposes

TROX[®] TECHNIK

 **Auranor**

TROX Auranor Norge AS

PO Box 100
NO-2760 Brandbu

Telefon +47 61 31 35 00
Telefaks+47 61 31 35 10
e-mail: firmapost@auranor.no
www.trox.no

TIH

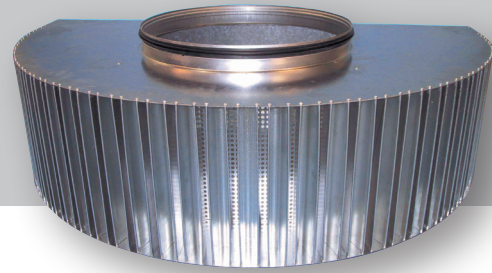

APPLICATION

The TIH diffuser is ideal for industrial premises as well as department stores, garage facilities and similar.

DESIGN

Available in 3 different designs and sizes, and comes with internal diffuser plate as standard.

TIH-1 for circular-duct connection (see fig. 1), TIH-2 for flat-duct connection and TIH-3 with circular connection collar. Annular design is available on request. NB! Remember to specify connection diameter (D2, fig. 2) when ordering TIH-1.

MATERIALS AND SURFACE COATING

Comes in a galvanised, steel-plated finish. Other materials and colours are available on request.

QUICK SELECTION

TIH	[m ³ /h]		
Dim.	30 dB(A)	35 dB(A)	40 dB(A)
315	830	1060	1300
400	1200	1500	2000
500	1700	2200	2700

Table 1: The table provides air flow rates at given sound power levels

ORDER CODE, TIH

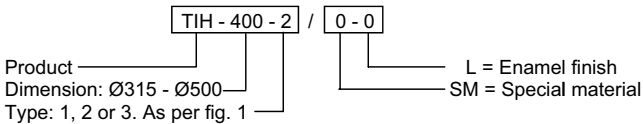

Example:
TIH-400-2 / 0-0
Explanation:
TIH, dim. Ø400, type 2.

DIMENSIONS AND WEIGHT, TIH

TIH	A	B	H	D	Weight [kg]
315	465	772	192	314	11
400	587	980	252	399	15
500	730	1225	315	499	20

Table 2: TIH

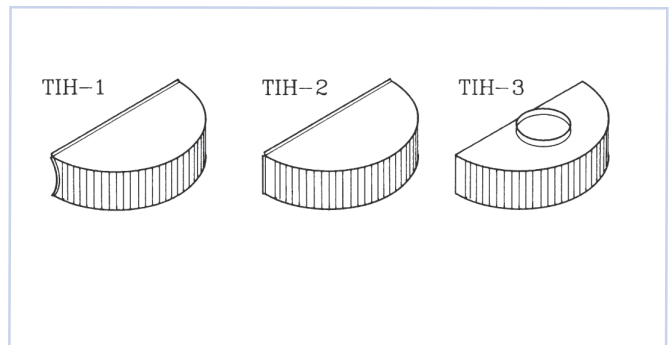

Fig. 1: TIH

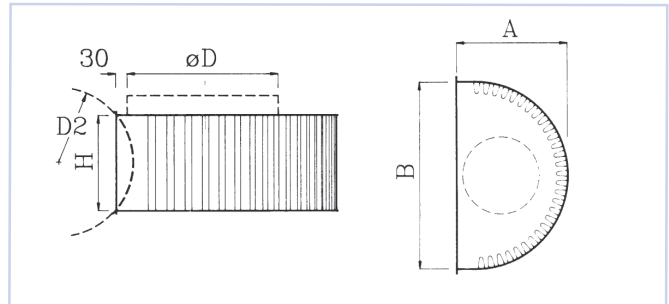
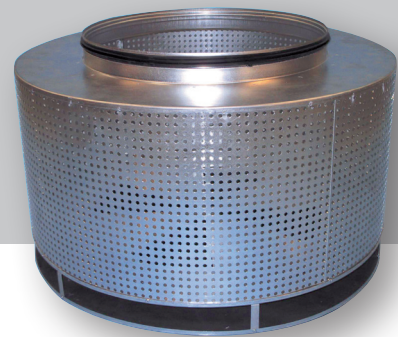

Fig. 2: TIH

TIR



APPLICATION

TIR is the ideal solution when high air flow rates are required, and is primarily intended as a freely suspended unit. It can, as an example, be used to supply hot or cold air to the occupied zone in rooms with high ceilings.

DESIGN

TIR comes with a perforated face-plate and with fixed slot-height to the diffuser cover which is also the absorption mat. Fitted underneath the face-plate is a string-operated sector shutter where the air flow rate, and thus also the supporting air jet and throw length, are regulated. With a deflector, the slot can be adjusted to provide a vertical air flow (see fig. 4, last page).

MATERIALS AND SURFACE COATING

Supplied in a galvanised, steel-plated finish. Other materials and colours are available on request.

QUICK SELECTION, TIR

TIR Dim.	[m ³ /h]		
	30 dB(A)	35 dB(A)	40 dB(A)
315	1370	1620	1870
400	1800	2090	2500
500	2500	2900	3300
630	3300	4100	4700
800	4900	5800	6700

Table 3: The table provides air flow rates at given sound power levels

ORDER CODE, TIR

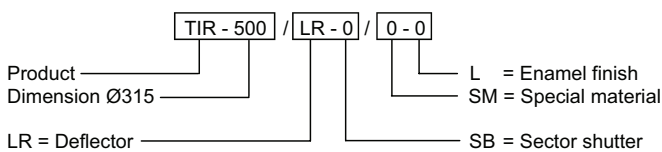

Example:
 TIR-500/ LR-0 / 0-0
 Explanation:
 TIR, dim. Ø500, equipped with deflector.

DIMENSIONS AND WEIGHT, TIR

TIR Dim.	A	B	H	Vekt [kg]
315	480	314	235	7
400	630	399	295	10
500	780	499	360	14
630	880	629	500	18
800	960	798	650	22

Table 4, TIR

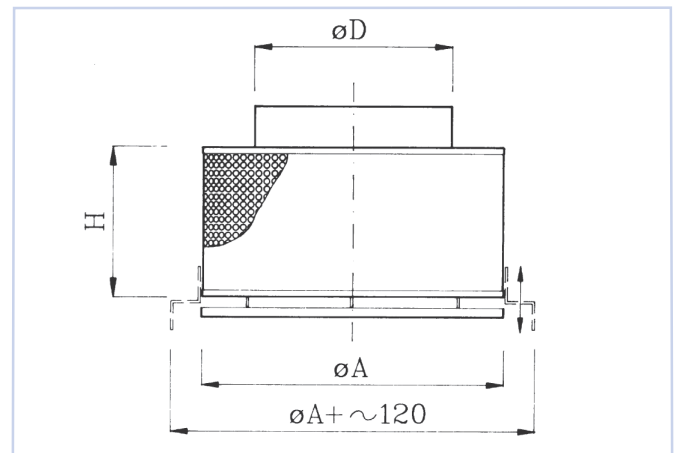

Fig. 3, TIR

TIH and TIR

ACOUSTIC DATA

The diagrams provide a summary of the A-weighted sound power level from diffuser, L_{WA} . A room with absorption equivalent to $10m^2$ Sabine will have a sound pressure level which is 4 dB below the sound power level emitted.

Example:

A production area requires an air flow rate of 800 l/s, and for this purpose a TIR Ø500 is used. Room attenuation is 5 dB. From the diagram, we find that $L_{WA} = 35$ dB(A) and the total pressure loss is 26 Pa. A room attenuation equivalent to 5 dB provides a sound pressure level in the room of: $35 - 5 = 30$ dB(A).

CALCULATION DIAGRAMS

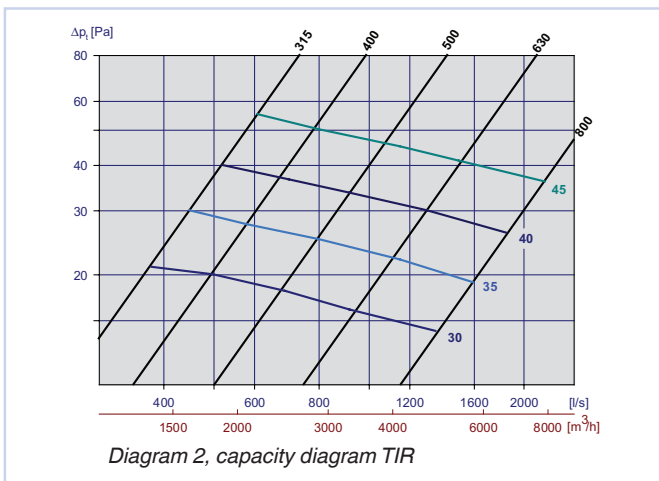
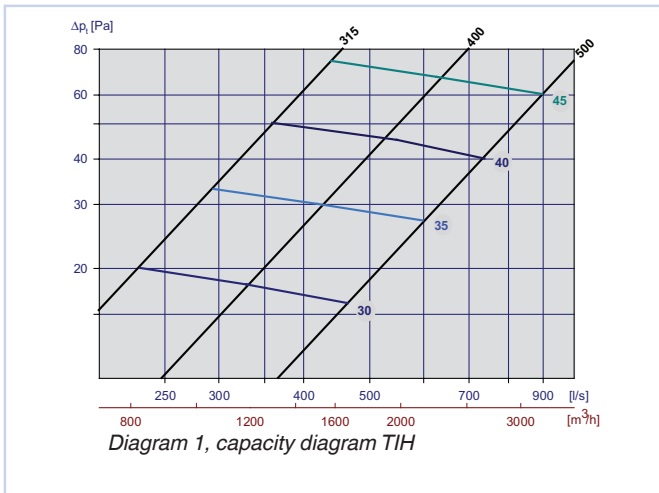

TIH and TIR

FLOW PATTERN

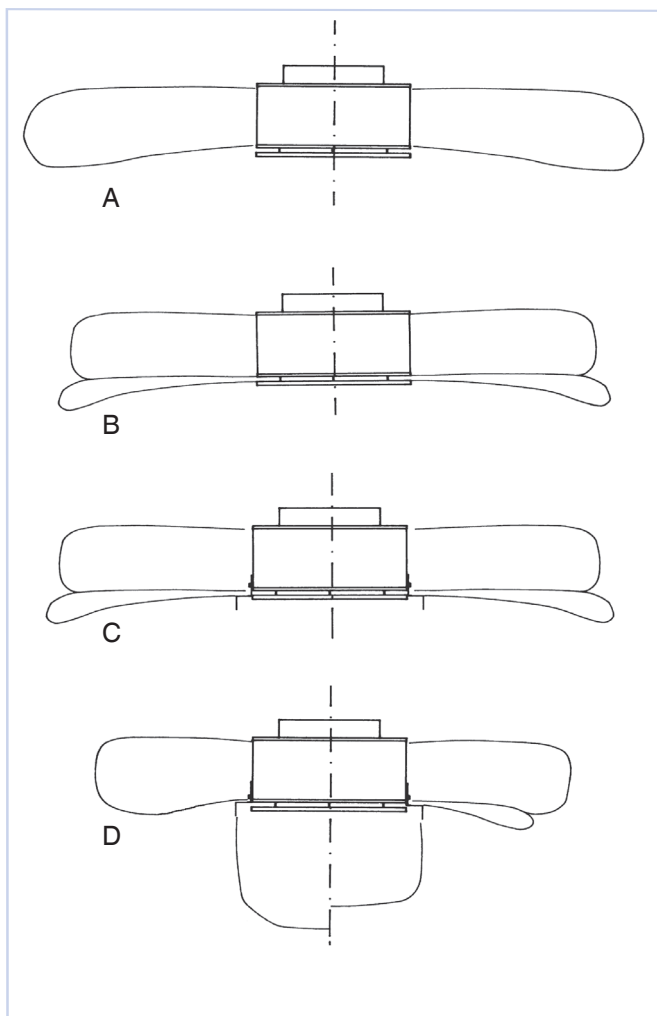

Figur 4

Explanation, fig. 4:

A: Air flow pattern with damper closed.

B: Air flow pattern with damper open.

The damper enables infinitely variable adjustment of the supporting air jet.

C: Deflector in lower position provides an air flow pattern as shown in fig. A and B

D: Deflector in upper position (left section) provides a vertical air flow which is infinitely variable and can be adjusted by using the damper (flow rate) and the deflector's height positioning. With the deflector in centre position (centre of the slot), it is possible to achieve a combination of vertical as well as horizontal air supply with supporting air jet as shown in fig. 4 (right section).

INSTALLATION

TIH-1 and 2 are equipped with flange for attachment to duct.

ENVIRONMENT

Enquiries regarding product declaration can be directed to our sales team, or information can be found at www.trox.no

TIH and TIR is developed and manufactured by:

The company reserves the right to make amendments without prior notice.