

Opus-4 and Opus-5

Diffuser for installation directly in duct

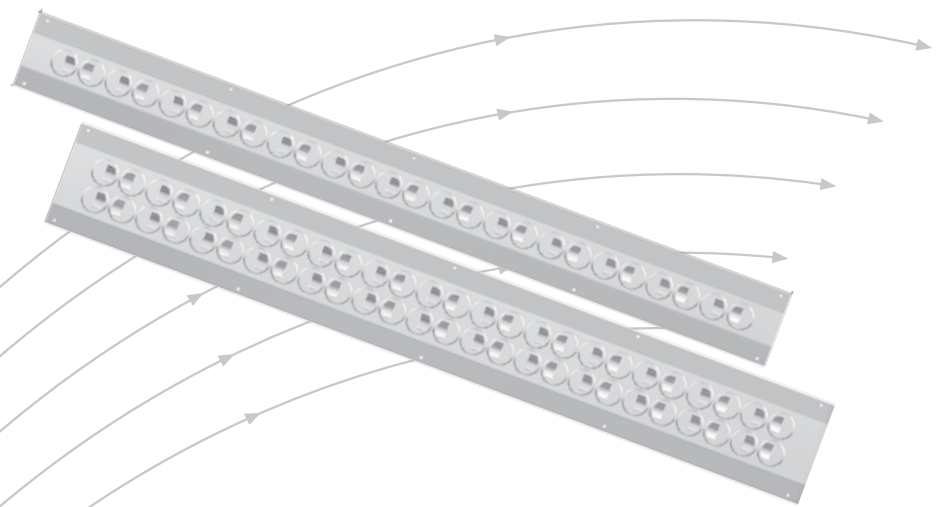

- For circular and rectangular air ducts
- Integrated diffuser plate
- Adjustable flow pattern
- Available in galvanised design

TROX[®] TECHNİK

 **Auranor**

TROX Auranor Norge AS

PO Box 100
NO-2712 Brandbu

Telephone: +47 61 31 35 00

Fax: +47 61 31 35 10

e-mail firma@auranor.no

www.auranor.no

Opus-4 and Opus-5

APPLICATION

Opus-4 and Opus-5 are rectangular supply diffusers fitted to the side of circular and rectangular air ducts. The diffusers offer an adjustable flow pattern and are ideal for both under- and overheated air. Duct velocity ahead of the first diffuser should not exceed 5 m/s.

DESIGN

Opus-4D and 4DD are made for installation in circular ducts, whereas Opus-5D and 5DD are designed for installation in rectangular ducts. The diffusers are equipped with adjustable Opus nozzles. Each unit is fitted with a diffuser plate to the rear which ensures even distribution at the front. The system is available with one (D) or two (DD) nozzle rows. In addition to the standard dimensions, made-to-measure diffusers with different numbers of nozzles are also available. Please contact your local dealer for more information. The standard nozzle settings are shown in fig. 1.

MATERIALS AND SURFACE COATING

The diffusers are steel plated, with a RAL 9010 finish. Opus nozzles are in ABS plastic. Black RAL 9005, aluminium RAL 9006 and galvanised design can be provided on request. Other colours are also available, but without adjustable nozzles.

QUICK SELECTION

Product Type	[m ³ /h]		
	25 dB(A)	30 dB(A)	35 dB(A)
Opus-4D	75	95	120
Opus-4DD	150	190	240
Opus-5D	75	95	120
Opus-5DD	150	190	240

Table 1: The table shows airflow rates at given sound power levels. (Duct velocity ahead of first diffuser ≤ 5 m/s).

ORDER CODE

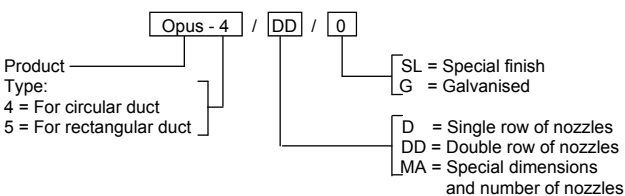

Example:
Opus-4 / DD / 0
Explanation:
Opus-4 for circular duct, double nozzle row

DIMENSIONS AND WEIGHT, Opus-4 and Opus-5

Opus-4D with single nozzle row is suitable from and incl. dim. Ø200 to and incl. dim. Ø1000. Opus-4DD with double nozzle row is suitable from and incl. dim. Ø315 to and incl. dim. Ø1250.

Product	Weight [kg]	Groove dimensions [mm]
Opus-4D	1,3	950 x 60
Opus-5D	1,3	950 x 60
Opus-4DD	1,7	950 x 95
Opus-5DD	1,7	950 x 95

Table 2

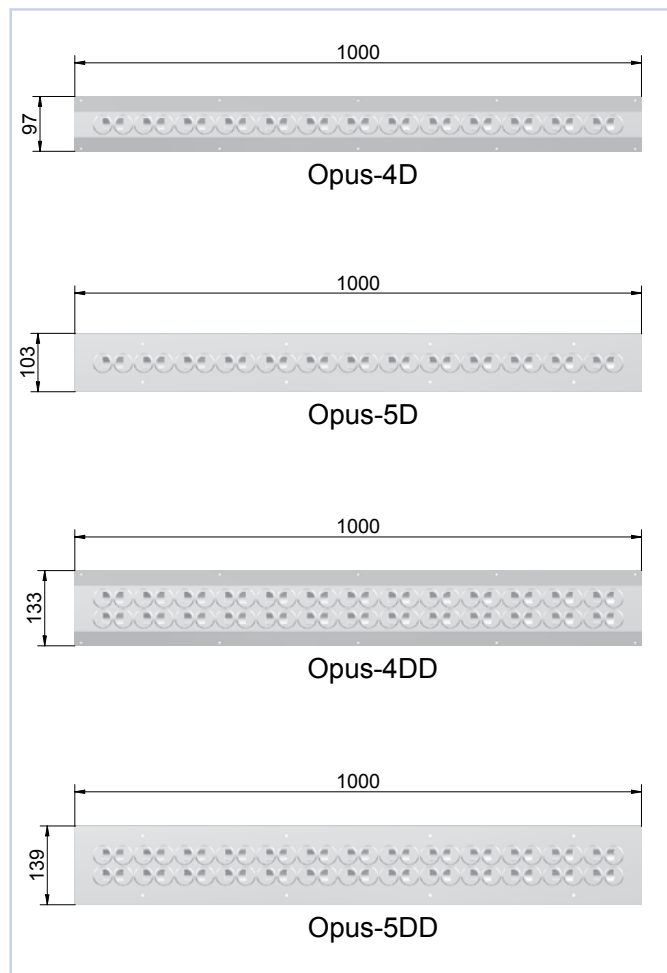

Fig. 1

Opus-4 and Opus-5

ACOUSTIC DATA

The diagram provides a summary of the A-weighted sound power level from diffuser, L_{WA} . Correction factors in table 4 are used to calculate emitted sound power level at the respective frequencies, $L_W = L_{WA} + KO$. A room with absorption equivalent to 10 m² Sabine will have a sound pressure level which is 4 dB below the sound power level emitted.

Example:

Opus-4, 25 l/s, 30 Pa

According to the diagram, $L_{WA} = 29 \text{ dB(A)}$.

We aim to find:

- a) Emitted sound power level at 250 Hz
- b) A-weighted sound pressure level in an office.
 - a) The correction factor is 0 dB. Emitted sound power level at 250 Hz is thus: $L_W = L_{WA} + KO = 29 + (0) = 29 \text{ dB}$
 - b) If we assume a room absorption equivalent to 10 m² Sabine, the A-weighted sound pressure level will be: $29 - 4 = 25 \text{ dB(A)}$

THROW LENGTHS

Throw lengths for the various air flow rates are shown in diagram 2.

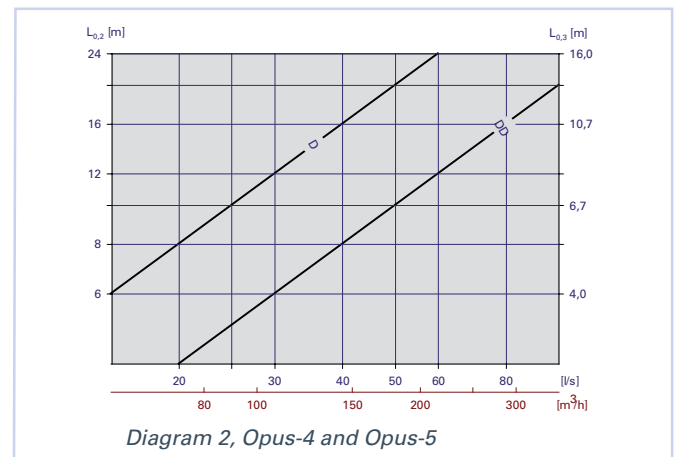

CALCULATION DIAGRAM

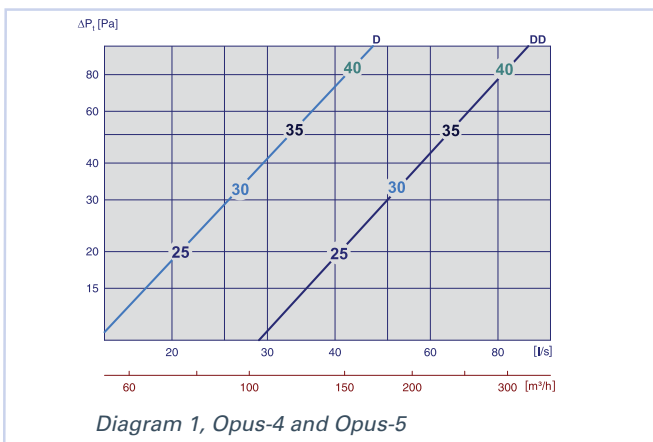

FLOW PATTERN

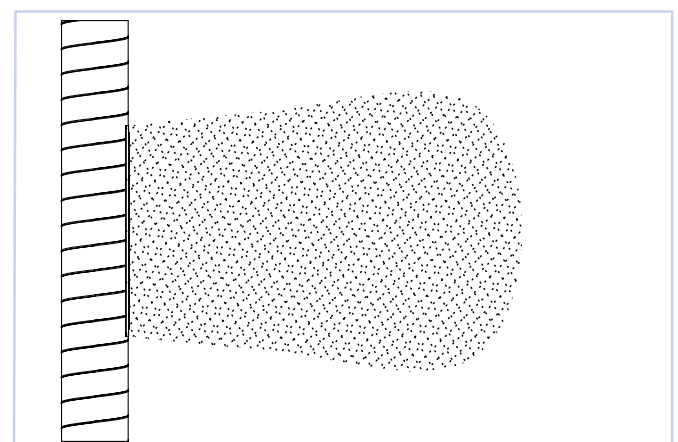

Sound attenuation:

The table provides an example of the diffuser's static sound attenuation including end reflection when mounted in duct dim. Ø200. A smaller duct diameter will increase attenuation, and a larger duct diameter will reduce attenuation.

Opus-4 and Opus-5		Attenuation [dB]						
Hz	63	125	250	500	1k	2k	4k	8k
	18	16	12	7	5	4	6	6

Table 3

Correction factor [KO]

Opus-4 and Opus-5		KO [dB]						
Hz	63	125	250	500	1k	2k	4k	8k
	2	4	0	-8	-17	-26	-28	-20

Table 4

Opus-4 and Opus-5

INSTALLATION

Grooves in ducting are made as described below and shown in fig. 3. The diffuser plate and front panel are positioned over the groove and attached by using the screws provided.

Opus-4D and Opus-5D, grooves in ducting:

L= 950, H=60

Opus-4DD and Opus-5DD, grooves in ducting: L= 950, H= 95

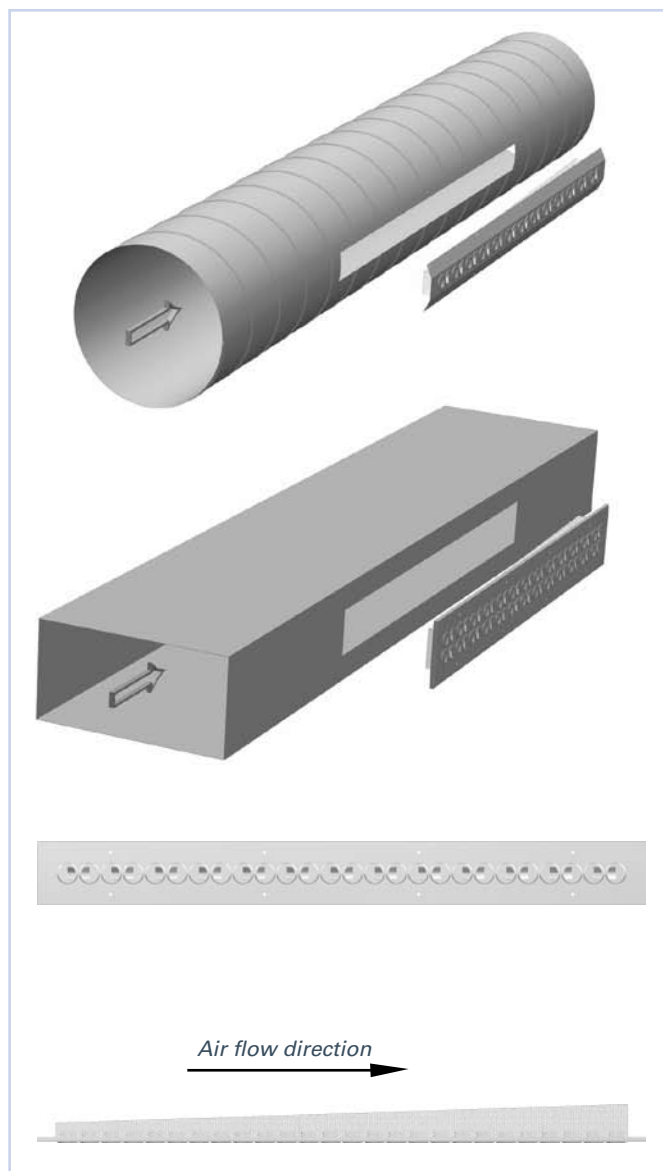

Fig. 3 Installation

Opus-4 and Opus-5 is developed and manufactured by:

TROX[®] TECHNIK
 **Auranor**

COMMISSIONING

For commissioning, use of damper in duct ahead of first diffuser is recommended.

MAINTENANCE

The diffuser can be cleaned by using a damp cloth.

ENVIRONMENT

Enquiries regarding product declaration can be directed to our sales team, or information can be found at our website: www.auranor.no

The company reserves the right to make amendments without prior notice.

Head Office:
TROX Auranor Norge AS, PO Box 100, NO-2712 Brandbu
Telephone: +47 61 31 35 00 Fax: +47 61 31 35 10
www.auranor.no